

# ROTO Overview 2022

**MKT PRODUCT**

June 2022

**MERLO**



# Index

---

1. The range
2. Machine structure
3. Frame and axle module
4. Powertrain module
5. Cab module
6. Electrical and safety system
7. Boom and hydraulic system
8. Main equipment
9. Main OPT
10. Roto Plug-In

# The range

# ROTO

The **ROTO** rotating telehandlers allow 360° operation thanks to the rotating turret, which offers a greater range of action compared to a fixed telehandler. This family marked the beginning of a new era by introducing new standards for telehandlers for the construction sector and expanding the product range with new contents, meeting the needs of different users.



1991



2022



# The ROTO offering

---

The ROTO models are included in **three different ranges**:



**ROTO 21-30**



**ROTO 35-28**



**ROTO 40**

# The ROTO offering

<b>ROTO 40</b>	<b>Entry Models</b>			
		Rotation	Capacity	Height
	ROTO40.16	415%	4.000 kg	15,7 m
	ROTO40.18	415%	4.000 kg	17,6 m
	<b>S-Classic Models</b>			
		Rotation	Capacity	Height
ROTO40.16S	415%	4.000 kg	15,7 m	
ROTO40.18S	415%	4.000 kg	17,6 m	
<b>ROTO 50</b>	<b>Entry Models</b>			
		Rotation	Capacity	Height
	ROTO50.21	600	4.950 kg	20,8 m
	ROTO50.26	600	4.950 kg	26 m
	<b>S-Classic Models</b>			
		Rotation	Capacity	Height
	ROTO50.21S	360%	4.950 kg	20,8 m
	ROTO50.26S	360%	4.950 kg	26 m
ROTO50.30S	360%	4.950 kg	29,2 m	
ROTO70.24S	360%	7.000 kg	24,2 m	

# The ROTO offering

---

S-Plus ROTO range	S-Plus Models			
		Rotation	Capacity	Height
	ROTO50.21S Plus	360%	4.950 kg	20,8m
	ROTO50.26S Plus	360%	4.950 kg	26m
	ROTO50.30S Plus	360%	4.950 kg	29,5m
	ROTO70.24S Plus	360%	7.000 kg	24m
	ROTO50.35S Plus	360%	4.950 kg	34,2m
	ROTO70.28S Plus	360%	7.000 kg	28m

# Range line-up

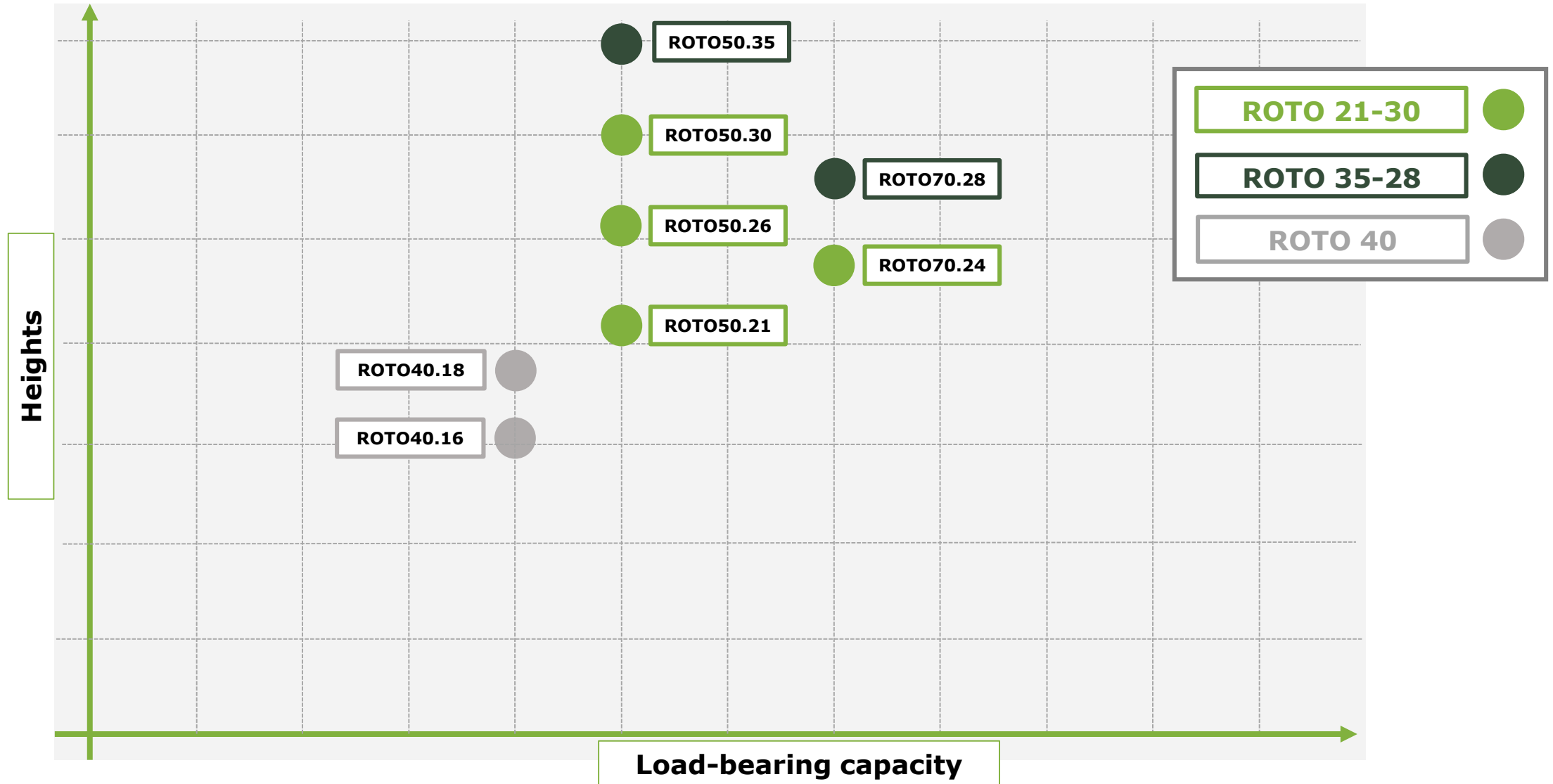



# Range

---

The ROTO machines with 415-degree rotation are available in two different versions:

- **Entry**
- **S-Classic**

	<b>Entry</b>	<b>S-Classic</b>
Chassis suspensions	NO	YES
Multifunction display	YES	YES
Engine power	75 HP	122 HP
Maximum speed	25 km/h	40 km/h
Hydraulic	LS + FS	LS + FS
Capacitive joystick	YES	YES
Software for variable stabilisation management	NO	NO

# Range

---

The **ROTO machines in the Entry version** with 600-degree rotation and **S-Classic version** with continuous 360-degree rotation are equipped as follows:

	<b>Entry</b>	<b>S-Classic</b>
Chassis suspensions	NO	YES
Multifunction display	YES	YES
Engine power	75 HP	170 HP
Maximum speed	25 km/h	40 km/h
Hydraulic	LS + FS	LS + FS
Capacitive joystick	YES	YES
Software for variable stabilisation management	NO	NO

# Range

---

The **S-Plus version ROTO** machines feature 360-degree continuous rotation and are equipped as follows:

	S-Plus
Chassis suspensions	YES
Multifunction display	YES
Engine power	170 HP
Maximum speed	40 km/h
Hydraulic	LS + FS
Capacitive joystick	YES
Software for variable stabilisation management	YES

# Areas of application





# Machine structure

# Winning equipment

Merlo interface with hydraulic locking and tool recognition

High safety, FOPS, ROPS and ASCS system

Tiltable and spacious cab, smart armrest



Axle levelling and suspension system

Longitudinal engine and EPD hydrostatic transmission

Contained chassis dimensions and high ground clearance

# The modular concept

---



The machine is divided into individual modules to maximise product versatility and customisation.

Furthermore, production by modules allows the quality inspection to be improved throughout the production cycle.

## ***Customer benefits:***

- ✓ Higher production quality
- ✓ Greater product customisation
- ✓ Greater design speed

# Load diagram - On stabilisers

	Max. capacity	Max. height	Max. reach	Load capacity at max. height	Load capacity at max. reach
ROTO40.16	4.000 kg	15,7 m	13,2 m	2.500 kg	700 kg
ROTO40.18	4.000 kg	17,6 m	15 m	3.000 kg	400 kg
ROTO50.21	4.950 kg	20,8 m	17,9 m	2.500 kg	800 kg
ROTO50.26	4.950 kg	26 m	22,9 m	1.500 kg	150 kg
ROTO50.30S	4.950 kg	29,2 m	25,4 m	2.000 kg	400 kg
ROTO50.35S Plus	4.950 kg	34,2m	27 m	2.000 kg	500 kg
ROTO70.24S	7.000 kg	24,2 m	20,5 m	3.000 kg	900 kg
ROTO70.28S Plus	7.000 kg	28 m	23,2 m	3.000 kg	850 kg

The best load diagrams are obtained on stabilisers. When the machine is stabilised, the diagram is the same through all 360° of turret rotation.



# Load diagram - On wheels

On the ROTOs the maximum diagram on tyres is declared both with turret aligned and rotated by 180°, while on competitor's machines the maximum diagram is declared to be only with aligned turret (with turret rotated by 180° the reduced diagram on tyres is declared as with turret rotated by 90°).

## **Customer benefits:**

Significantly better stability with turret rotated by 180°.

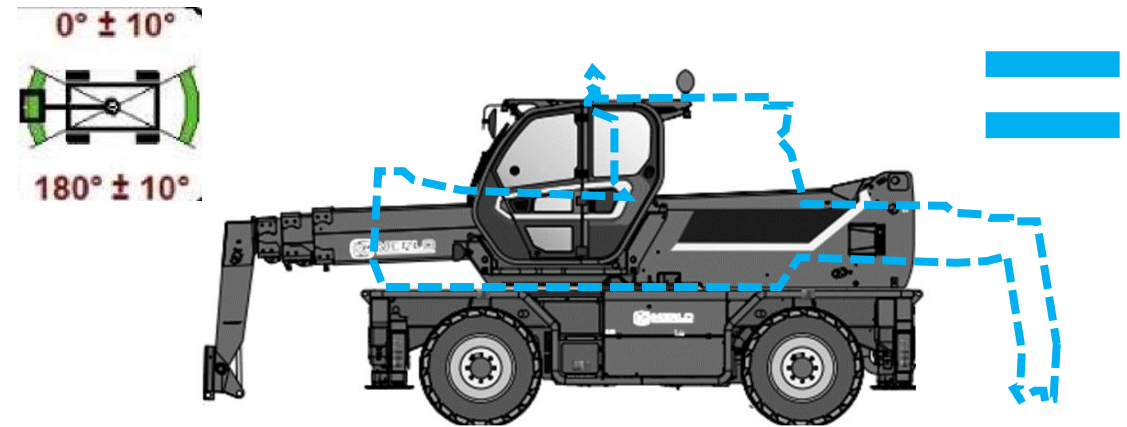

# Frame and axle module

# Frame

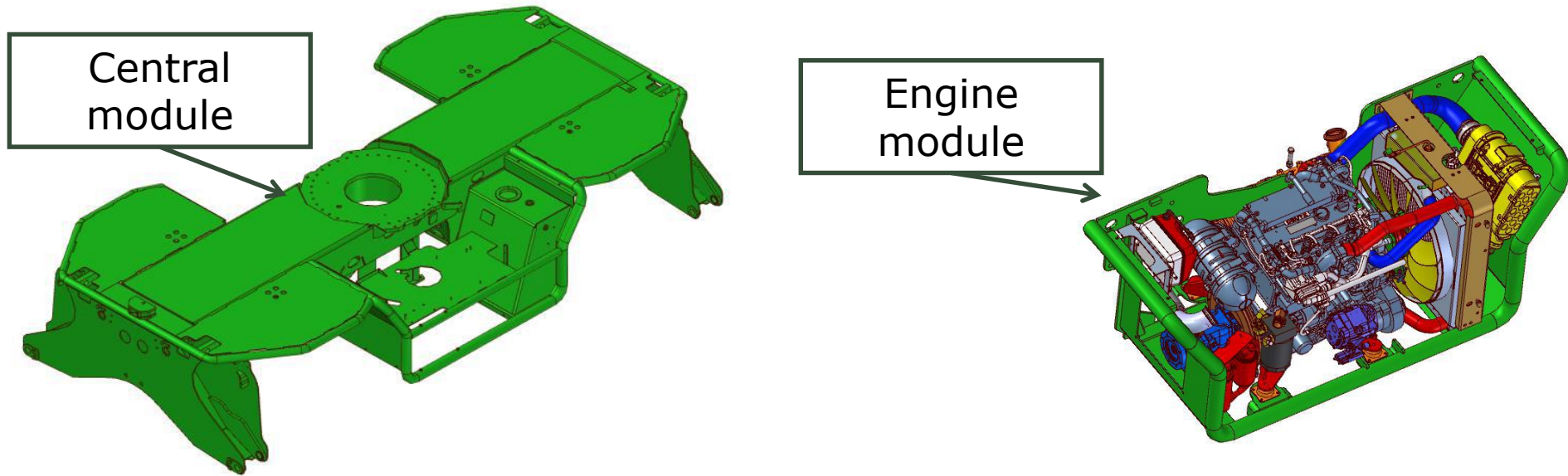

The chassis of the ROTO ranges is divided into two sub-components.

- **Central module** – which acts as a support for the entire machine by housing axles and tanks.
- **Engine module** – on which the powertrain is set up with the different engines.

# Steel belt

The chassis is equipped with a steel belt, a full steel bar with a cold bent 70 mm diameter.

## ***Customer benefits:***

- ✓ Lower height of the machine's centre of gravity
- ✓ Greater protection of components against shocks and accidents
- ✓ Perfect weight distribution





# Walkable surface



Upper part of the steel chassis, completely walkable. It allows you to leave the cab in any turret position, facilitating access in case of extraordinary maintenance.



## ***Customer benefits:***

- ✓ Greater ease of machine use
- ✓ Greater access for extraordinary maintenance
- ✓ Greater protection of chassis components

# Anchor rings

---



Machine anchor points. Anchoring integrated on the chassis as standard, external anchors optional.

This solution facilitates transport by truck and allows the lifting of the machine.

***Customer benefits:***

- ✓ Greater ease and safety for transport
- ✓ Greater standard equipment
- ✓ Greater machine versatility



# Transport kingpin



The transport kingpin can be put on and taken off the ground and with the boom in all positions.

# Frame - Left side



Batteries, tanks (hydraulic oil, diesel and urea), hydraulic distributors and electronic components are all installed on the left side of the chassis, below the cab.

### ***Customer benefits:***

- ✓ Greater accessibility for topping up
- ✓ Greater accessibility for maintenance
- ✓ Components protected against impact and damage

# Suspended frame

The S-Classic and S-Plus models are equipped with active axle suspensions as standard. These can be managed in three ways:

- **Active suspensions**
- **Manual management** (levelling and machine height variation)
- **Locked suspensions**

The solution has been designed to maximise efficiency in the transfer phase and to improve comfort during manoeuvres.

## ***Customer benefits:***

- ✓ Increased comfort during transfer
- ✓ Chassis levelling for lifting loads on wheels
- ✓ Less vibrations transmitted to the moved loads

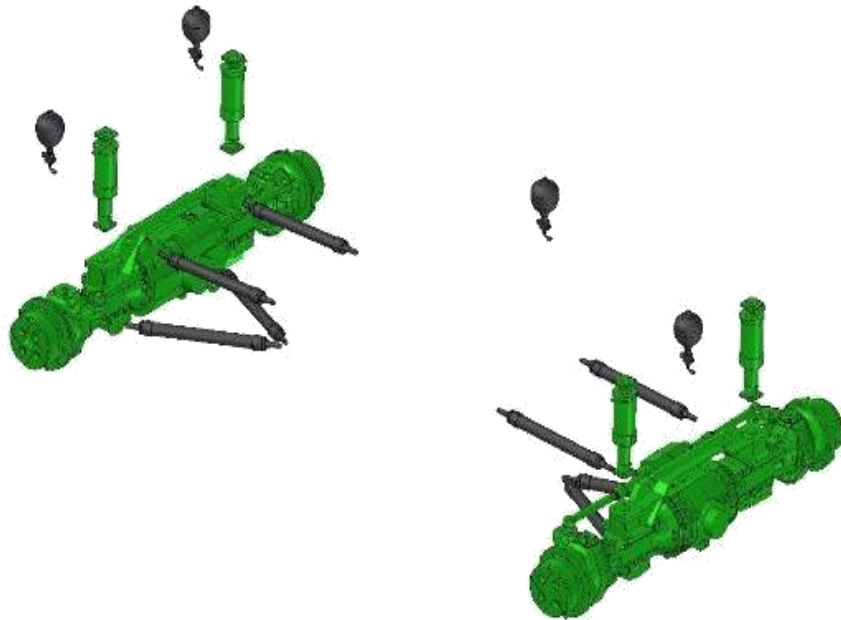

# Suspended frame



**Low position**



**High position**



**Detail**

Possibility of varying the height of the machine according to the soil.



# Suspended frame



Approach angle



By varying the height, the approach and departure angle of the machine is changed.

# Suspended frame



**Transversal** levelling (+/- 12%)



**Longitudinal** levelling (+/- 4%)



Possibility of having transversal and longitudinal levelling.



# Stabilisers – ROTO 40

---



With **ON/OFF type stabilisers** with hinged movement, it is possible to operate the stabiliser automatic positioning device.

By independently managing them, it is possible to correct terrain slopes up to 3 degrees.

# Stabilisers – ROTO 50 and ROTO 70

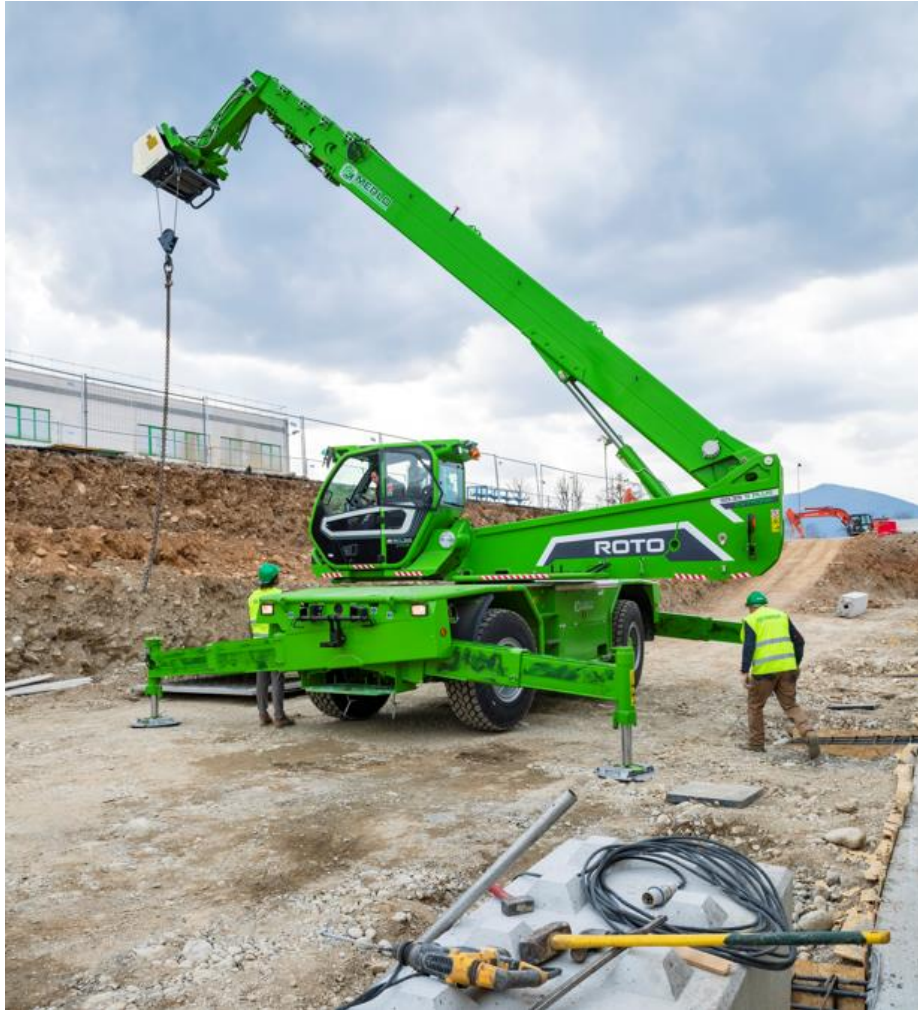

**MULTI-POSITION** stabilisers ensure the possibility to deploy the stabilisers and set them in any position, from "fully retracted" to "fully extended". The stabiliser automatic positioning device can be operated.

There are two safety systems:

- **SIMPLIFIED** safety system
- **PLUS** system

# Stabilisers – ROTO 50 and ROTO 70

---



By managing the stabilisers independently, it is possible to correct ground slopes up to 6 degrees and vary the stability plan according to the conditions of the site.



# Turret overhang

---



The ROTO machines are designed to minimise the turret side and rear overhang.

***Customer benefits:***

- ✓ Smaller machine overall dimensions
- ✓ Greater safety in the operational phase for a lower risk of accidental impact
- ✓ Greater ease of machine use

## Turret rotation – Rotation over 400°

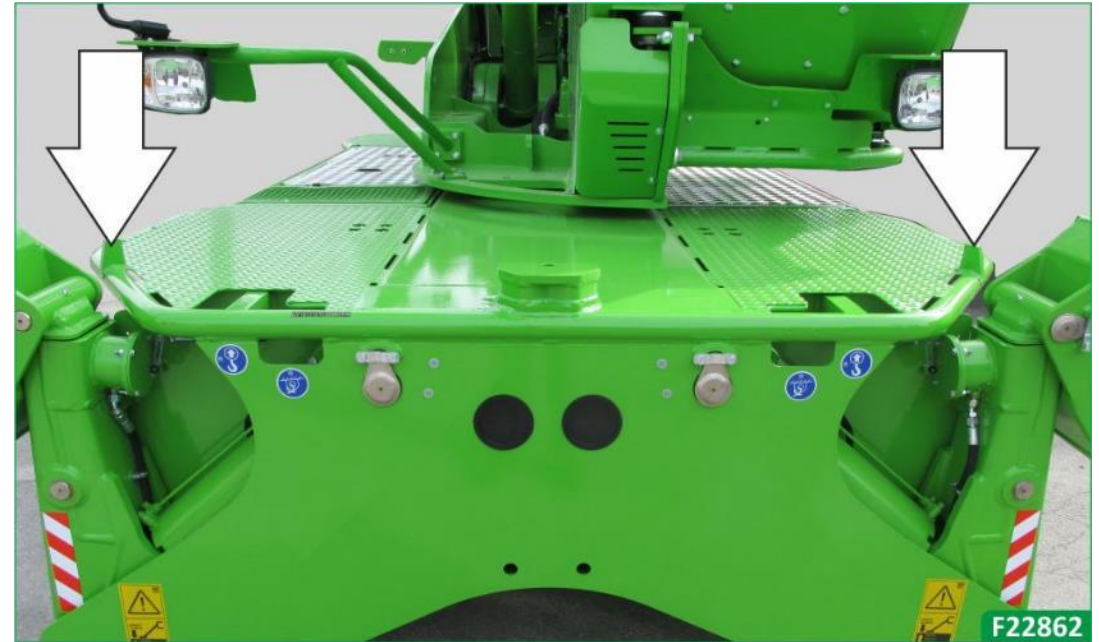

For ROTO40 models (all models and versions) the maximum turret rotation is 207 degrees per side, the machine is equipped with a mechanical stop to limit rotation.



# Turret rotation – Rotation over 600°

---



For ROTO50.21 and ROTO50.26 models, the maximum turret rotation is 300 degrees per side. For these models, the turret is equipped with an electronic stop to limit rotation. As the limit approaches, the rotation slows down and stops.



# Turret rotation – Continuous rotation

---



The ROTO S and ROTO SPLUS models are equipped with continuous rotation, with no limits in any direction.

# Underbody

---



The lower part of the frame is completely protected by steel sheets.

This greatly limits the risk of damage to transmission components.

## ***Customer benefits:***

- ✓ Greater protection
- ✓ Lower risk of impact and damage
- ✓ Greater ease of use of the machine

# Powertrain module

# Engines



## **Longitudinal and side engine.**

High accessibility to the main components for maintenance. Powercore type air filter, vertical radiators, and horizontal opening bonnet (maximum accessibility in all circumstances)

	<b>ROTO 40.16-40.18 Entry</b>	<b>ROTO 40.16-40.18 S-Classic</b>
Engine model	FPT F34	FPT F36
Displacement/cylinders	3.400cc / 4	3.600cc / 4
Engine power	55,4kW / 75 HP	90kW / 122 HP
Emissions	Stage V	Stage V
Systems	DOC + DPF	DOC + DPF + SCR (AdBlue)
Radiators	Vertical	Vertical

# Engines



## **Longitudinal and side engine.**

High accessibility to the main components for maintenance. Powercore type air filter, vertical radiators, and horizontal opening bonnet (maximum accessibility in all circumstances)

	<b>ROTO 50 Entry</b>	<b>ROTO 50 S-Classic</b>
Engine model	FPT F34	FPT NEF45
Displacement/cylinders	3.400cc / 4	4.500cc / 4
Engine power	55,4kW / 75 HP	125kW / 170 HP
Emissions	Stage V	Stage V
Systems	DOC + DPF	DOC + DPF + SCR (AdBlue)
Radiators	Vertical	Vertical



# Engines



## **Longitudinal and side engine.**

High accessibility to the main components for maintenance. Powercore type air filter, vertical radiators, and horizontal opening bonnet (maximum accessibility in all circumstances)

	<b>ROTO - All S-Plus versions</b>
Engine model	FPT NEF45
Displacement/cylinders	4.500cc / 4
Engine power	125kW / 170 HP
Emissions	Stage V
Systems	DOC + DPF + SCR (AdBlue)
Radiators	Vertical

# Radiators

---

The radiator includes **4 key parts:**

- 1 – hydrostatic oil cooler
- 2 – intercooler (if any)
- 3 – engine coolant cooler

There is a fine mesh filter outside the cooler to prevent clogging of the unit.

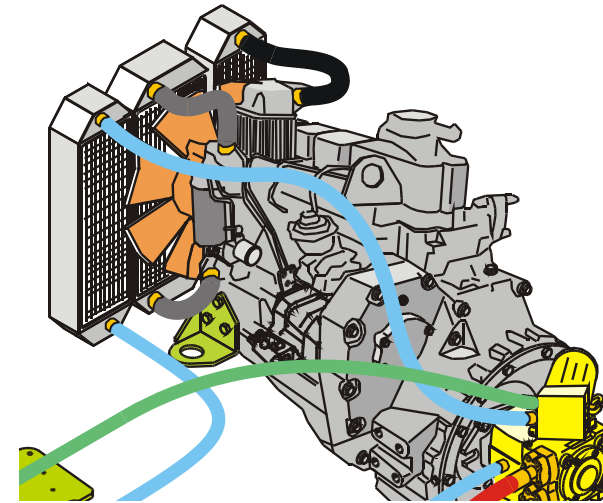

## ***Customer benefits:***

- ✓ Liquid cooling efficiency
- ✓ Greater machine performance
- ✓ Convenient radiator cleaning

# Transmission

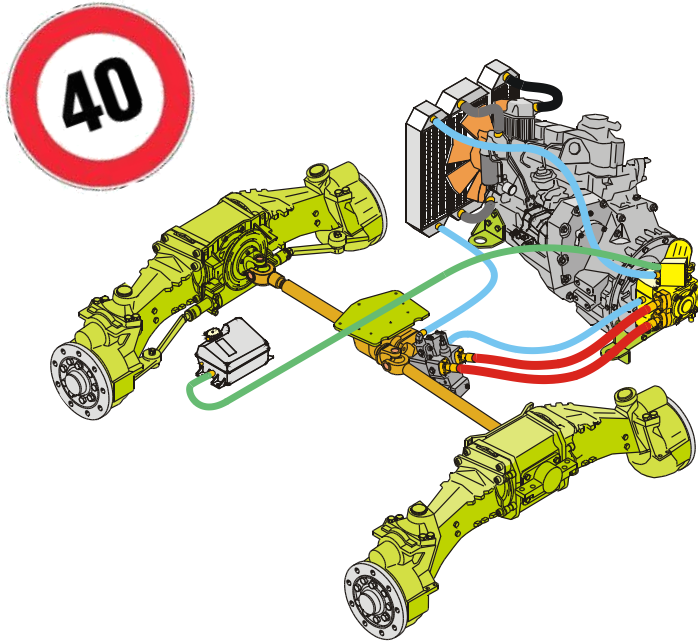

**Hydrostatic transmission** with high power and high dynamic braking: the machine remains stable even on steep slopes.

Ease of use and high operating precision in the movements; select the direction of travel and just touch the accelerator to move the machine.

Maximum speed of **40 km/h**.

## ***Customer benefits:***

- ✓ Greater transfer speed
- ✓ Greater operational safety
- ✓ Possibility to keep the vehicle static even on steep slopes

# Transmission

---



***It can overcome up to 50% slopes, depending on the situation***

Even on steep slopes, just touch the accelerator to move the machine.

**Possibility of stopping and restarting without any difficulty** for the operator. The machine is able to remain stationary even without the use of the brake.



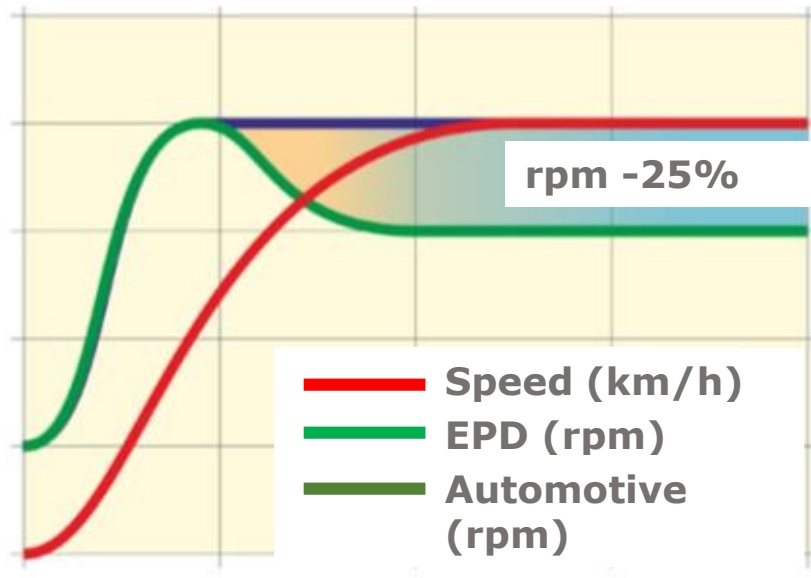

Hydrostatic transmission with electronic **Eco Power Drive - EPD** control.

It allows the RPM to be varied independently of the speed of the machine, reducing them when unnecessary in order to minimise energy waste.

### **Customer benefits:**

- ✓ High dynamic braking and precise movements
- ✓ Lower machine consumption
- ✓ Increased ease of use for the operator

# EPD: Self-accelerating joystick



By activating the automatic RPM management system by Joystick, the engine remains idling. At the request of hydraulic power (by operating the joystick), the engine revs increase automatically to provide the oil flow requested by the customer (up to a limit set via potentiometer **A**). At the end of the request, the engine will return idling. With a single movement you reach 80% of set rpm, with more than 1 movement you reach 100%. For smooth joystick movements (travel < 20%), engine RPM do not increase so as to ensure positioning accuracy. The RPM change does not affect the transfer speed!

## **Customer benefits:**

- ✓ Greater ease of use for the operator
- ✓ Lower consumption, the machine operates by default at minimum
- ✓ Greater performance and higher boom speeds

## 2-speed gearbox and CVTronic transmission

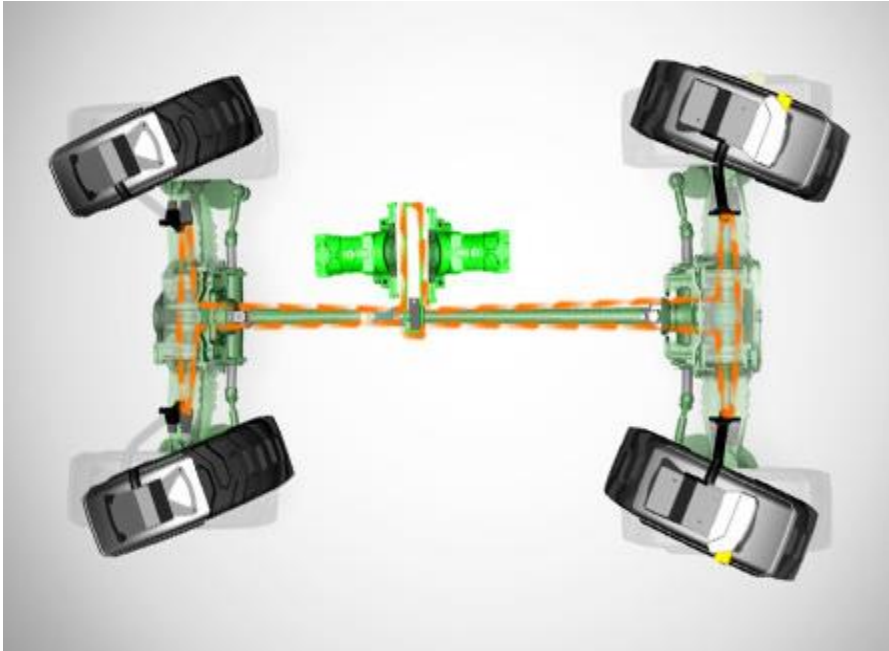

**2-speed gearbox**, slow and fast range according to customer requirements. Speed shifting takes place when the machine is stationary.

The “**CVT**” model (ROTO 35m e ROTO28m) is equipped with the **CVTronic (continuously variable transmission) system**, which ensures an acceleration from 0 to 40 km/h without torque or gear change interruption. The smart transmission automatically engages or disengages the gear at maximum torque even while driving.

### ***Customer benefits:***

- ✓ Higher starting torque at low speeds
- ✓ Automatic gear shift management
- ✓ Greater efficiency at high speeds

# Axles

**Two** distinct axle **solutions** available.

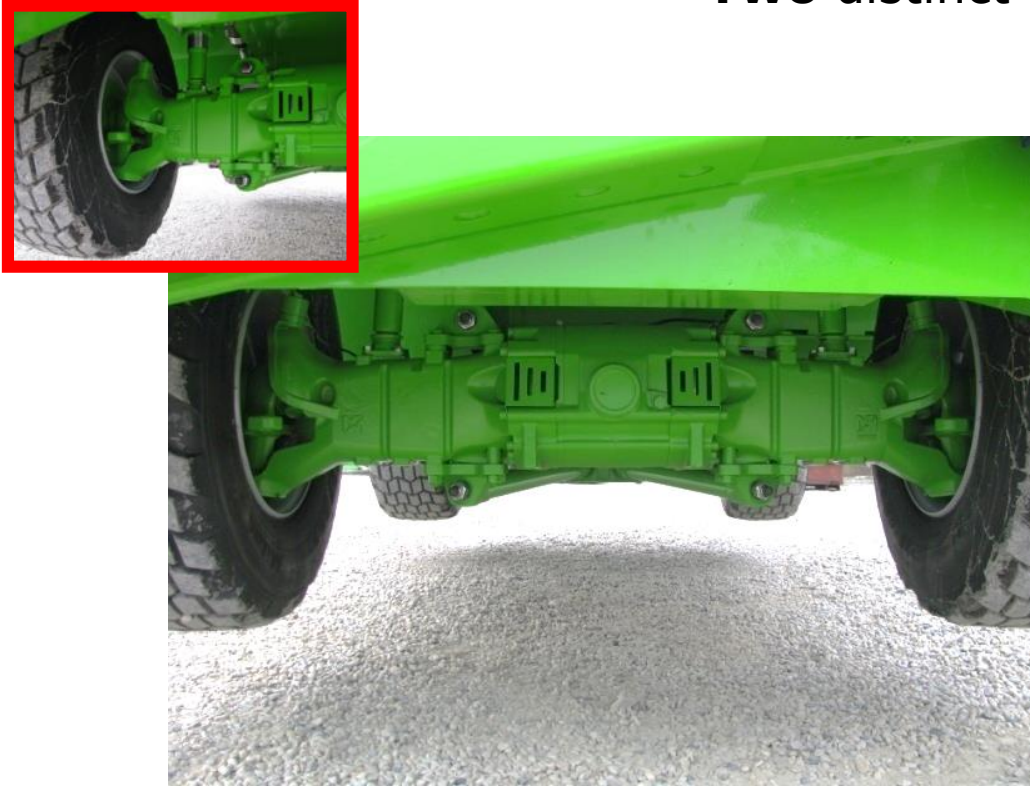

Axial, with planetary gear reducers



Portal, with cascade reducers



# Axles with epicyclic gear reducers

---



Axial, with planetary gear reducers

Axial solution, **with epicyclic gear reducers.**

Designed to transfer high torque to the wheels and reduce the height of the machine.

***Customer benefits:***

- ✓ Lower machine height
- ✓ Increased power drive
- ✓ High component reliability

# Epicyclic gear reducers

---

## Epicyclic gear reducer:

- Drive shaft aligned with the reducer
- CV joint to ensure precise and smooth steering
- Pinion - planetary - wheel hub connection

### ***Customer benefits:***

- ✓ High reduction ratios
- ✓ High torques to be transmitted
- ✓ High output shaft loads

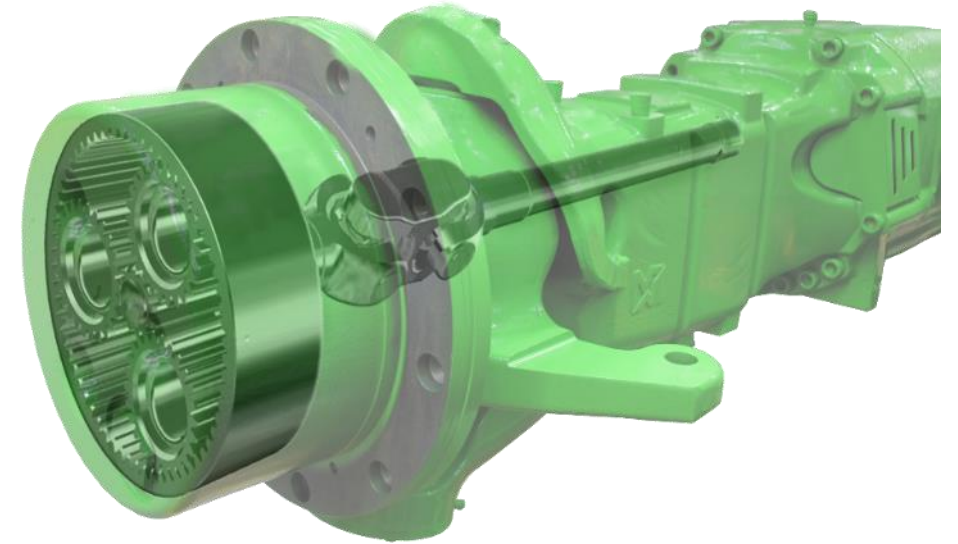

# Portal axles

---

## **Portal solution, with cascade reducers.**

Designed to increase the useful ground clearance for the benefit of machine accessibility and versatility of use. They are applied to the range ROTO40.16, ROTO40.18, ROTO50.21 and ROTO50.26.

### ***Customer benefits:***

- ✓ High ground clearance
- ✓ Increased machine accessibility
- ✓ High component reliability



Portal, with cascade reducers

# Wheel reducers

---

**Wheel reducers** (called RR700), designed to increase the strength of the structure and reduce the risk of oil leakage.

Constant velocity joint in the shaft to improve the behaviour of the wheel and the entire transmission during steering.

Sprocket pinion connection to raise the position of the shaft and axle, improving ground clearance.

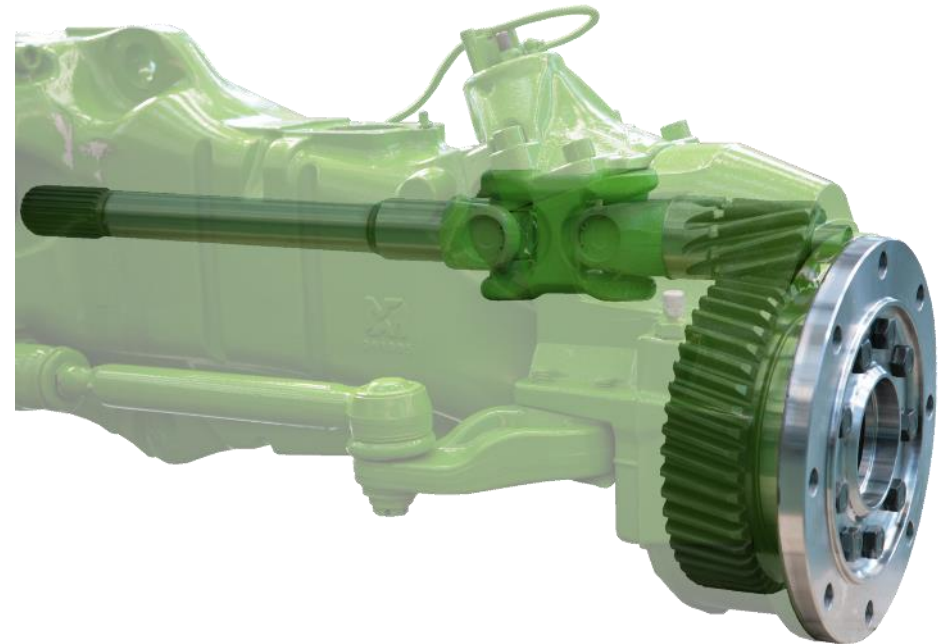



# Differential

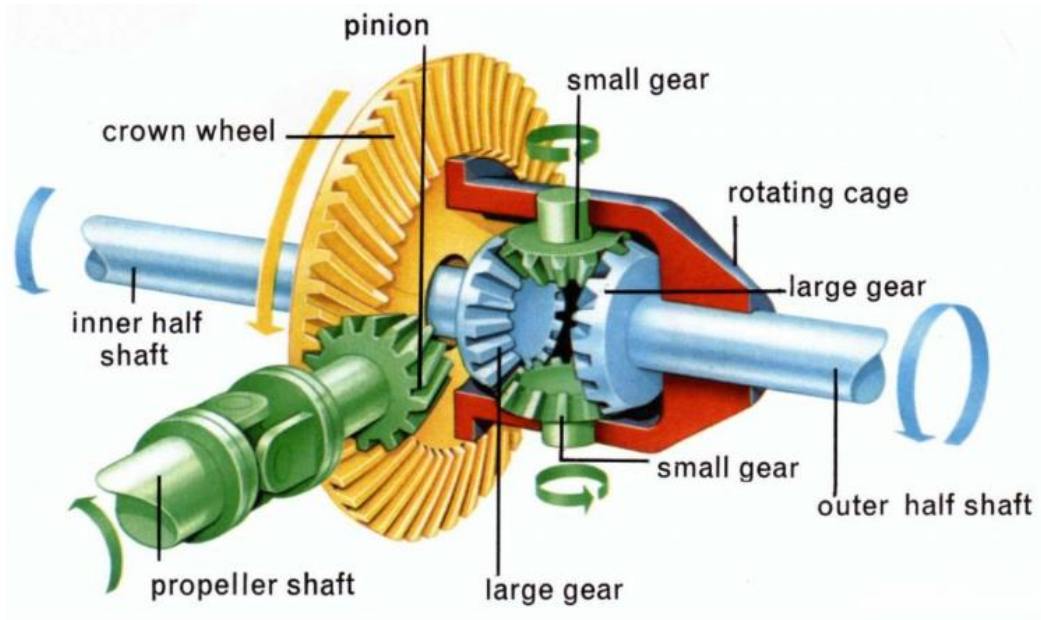

**Differential at the centre of the axle** to drive the two axle shafts.

Possibility of mounting the complete lock on both the rear and front axle.

The differential serves not only to transfer torque from the drive shaft to the wheels, but also to prevent the drive wheels from slipping when cornering, adapting their speed to the length of the trajectory.

# Brakes

---

**Dry disc brakes**, two per axle, to reduce fuel consumption and improve performance. The diameter and thickness of the brake are designed to ensure maximum braking torque even on steep slopes.

A parking brake is installed to the main shaft. The solution provides **manual or automatic activation** upon stopping the engine.

## ***Customer benefits:***

- ✓ Lower maintenance costs
- ✓ Increased machine efficiency
- ✓ Greater structural strength of the components



# Cab module

# Cab

## Merlo cab:

- FOPS (lev. II) with external windscreen protection and ROPS.
- 4,3 sq.m of glass surface for improved brightness and visibility.
- 1.010 mm width for operator comfort.
- Door opening: 180°.
- Fuel tank of 140 litres, mounted under the cab.
- Windscreen wipers and rear window wiper as standard.
- Pressurised, according to ISO 10263-3\*.

### **Customer benefits:**

- ✓ Perfect visibility in every direction
- ✓ Increased operator safety
- ✓ Excellent cab accessibility and comfort

*\*N.B.: pressurisation level is not sufficient for use of pesticides, work with asbestos, etc..*





# FOPS

---



Upper **protection grid outside** the cab. It guarantees FOPS II level protection. It can be removed for cleaning the glass roof.

# Cab accessibility

---



Lock-up mechanism positioned so that you can unlock the door from the ground, without any difficulty. Numerous handles to facilitate entry into the cab.

# Cab accessibility



Well-positioned and proportionate steps to access the cab.

### ***Customer benefits:***

- ✓ Easy access to the cab and easy use of the machine
- ✓ High internal brightness and visibility from the driver's seat
- ✓ More operational safety for the user



# Additional step

---



In the models with lifting heights over 21 metres, a second engine-side step is available to simplify access in all circumstances.



# Door opening: 180°



The door can be **fully opened** for quick and easy access to the cab. The upper part (the window) can be locked open to facilitate air exchange and direct contact with those working outside.

### ***Customer benefits:***

- ✓ Comfortable access
- ✓ Perfect ventilation
- ✓ Ease of use

# Visibility



The positioning of the cab, boom and all components ensures perfect visibility for the operator.

The only one on the market to offer, throughout the range, a **high level of visibility** all around the machine and excellent visibility on the implement in use.

Multiple-speed wipers for any situation.

### ***Customer benefits:***

- ✓ Greater safety when driving
- ✓ Simpler load handling
- ✓ Easier to use



# Visibility

## EXTERIOR



## INTERIOR



# Cab tilting



For the S-Plus models, the machine is equipped as standard with a cab with a tilting device, which allows it to be raised by 20°, guaranteeing load visibility in all circumstances.

### ***Customer benefits:***

- ✓ Best customer operating comfort
- ✓ Greater load visibility in the operational phases
- ✓ Easy to use



# Cab interior

**PREMIUM** configuration for high capacity models (higher quality upholstery, more ergonomic steering wheel, sun-shade in the cab) – available as an OPT on compact and medium-level models.

The interiors are designed to guarantee maximum accessibility to the controls and ergonomic features.

## **Customer benefits:**

- ✓ Easy to use
- ✓ Same interface on all models
- ✓ Better command ergonomics



# Cab interior



User interface with **TFT display** (automotive style) for displaying all operating parameters and liquid levels. Controls for the activation of lights and auxiliary systems with dedicated colours and high-finish materials. The **warning lights** are **grouped** on the right side of the dashboard to simplify monitoring.

# Joystick



**As an OPT, double RH/LH horizontal joystick control and double RH/LH vertical joystick control are available as well.**



**Capacitive electronic joystick control laid horizontally on armrest** with hand presence sensor on the handle. It is equipped as standard with the following controls:

- Selection of travel direction
- Turret rotation
- Auxiliary hydraulic functions
- Hydraulic movements of the boom

The capacitive sensor can recognise the operator's action even when operator is wearing gloves.

### ***Customer benefits:***

- ✓ Easy to use
- ✓ Greater comfort
- ✓ Greater ergonomics



# Variants included: AUX lock and Carriage rotation lock

- **Carriage rotation lock** to eliminate the risk of involuntary rotation when operating at a height;
- **Auxiliary lock** to eliminate the risk of inadvertent activation of the hydraulic auxiliary device (example, tac-lock).



With these controls it is possible to inhibit the movement for the action of the hydraulic auxiliaries and for the rotation of the carriage.



# Variants included: Services oil continuous delivery

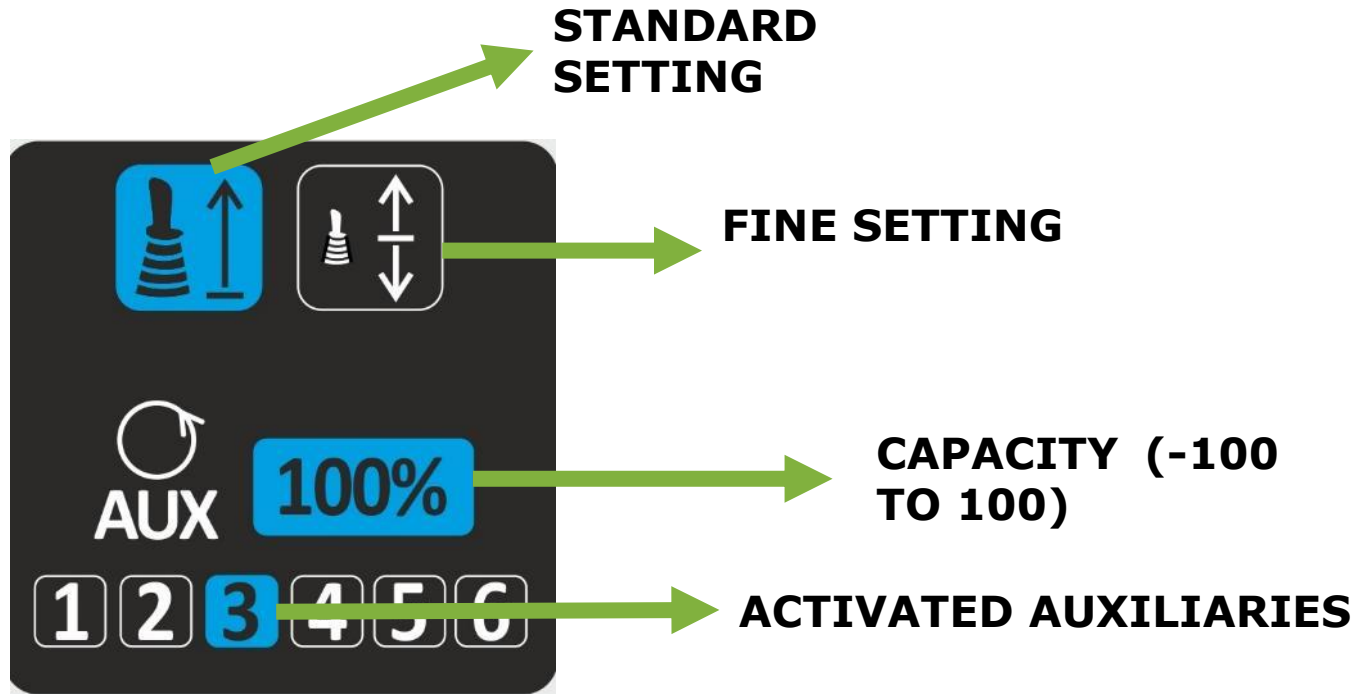

To activate the hydraulic fluid continuous delivery, press the special button located near the knob and work the joystick using the yellow AUX buttons on the back. Once the desired flow is reached, simply release the controls to have a continuous flow of fluid. Unlike in the past, by activating the function it is possible to adjust the oil flow according to the requirements of the implement. Regardless of the engine speed.

# Smart armrest



Three functional groups:

1. Controls for machine management
2. Joystick functionality
3. Safety system management

The multi-function armrest is integrated in the seat and sized to guarantee comfort to all operators.

## ***Customer benefits:***

- ✓ Greater ease of use and machine management
- ✓ Greater comfort for the operator
- ✓ Increased command implementation speed

# Smart armrest

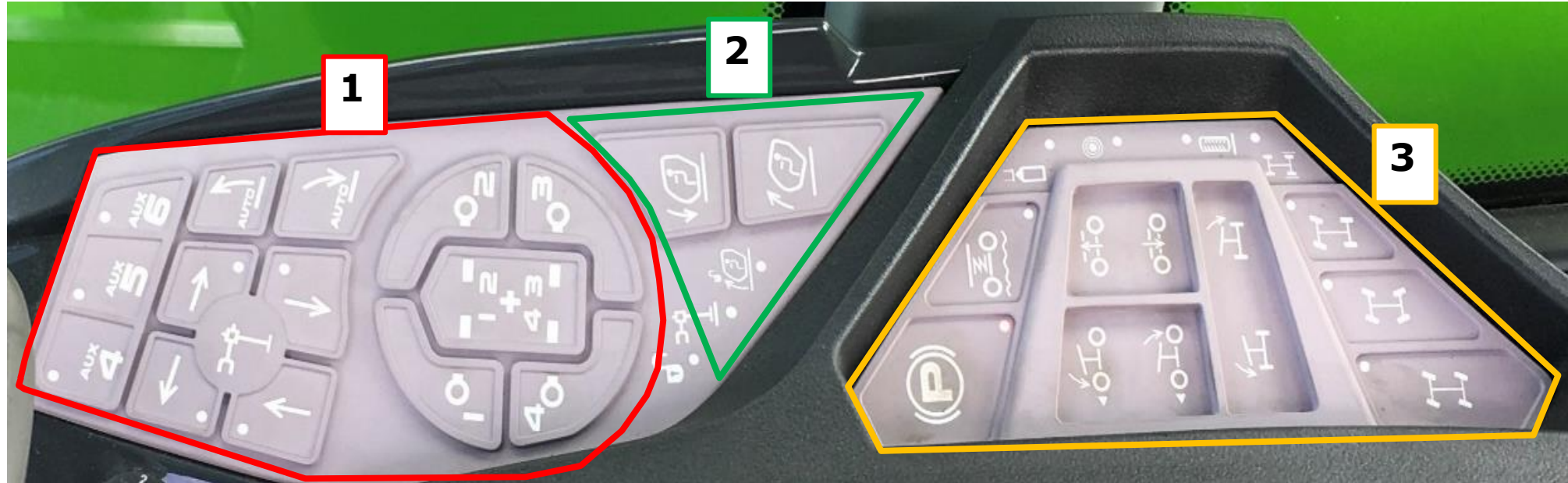

The controls, made with soft-touch materials, are divided into 3 functional groups:

1. Stabiliser management and self-stabilisation activation
2. Cab lift management (where present)
3. Basic truck management, brake activation, steering and suspension (where present)

# Airflow management

---

**Airflow management** for cab heating and cooling. Possibility to choose air direction and activate the windscreen demisting system.

More precise temperature and speed adjustment.

Defrost ventilation provides air to both the windscreen and rear window.

**Automotive-style solution.**

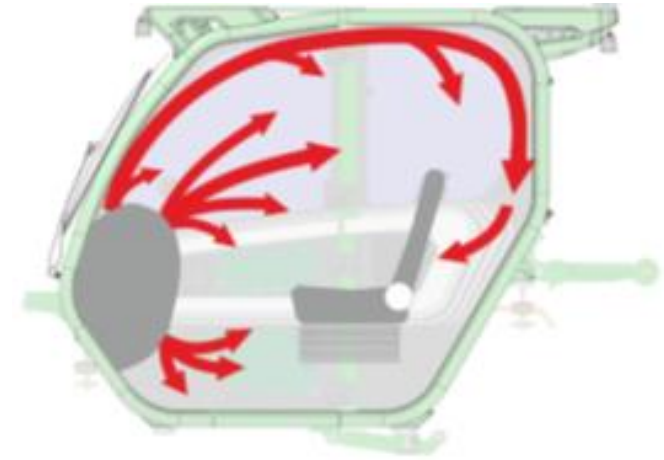



# Electrical and safety system

# Electrical system

---

Solution for the machine's electrical system featuring a clean layout, all cables are fixed to the chassis to ensure maximum safety.

Electrical system with IP65 rated system (having over 80% of IP67 connections).

For the first time, the electrical system is shared on all the Merlo ranges, in order to unify the diagnostic tools for the service technicians.

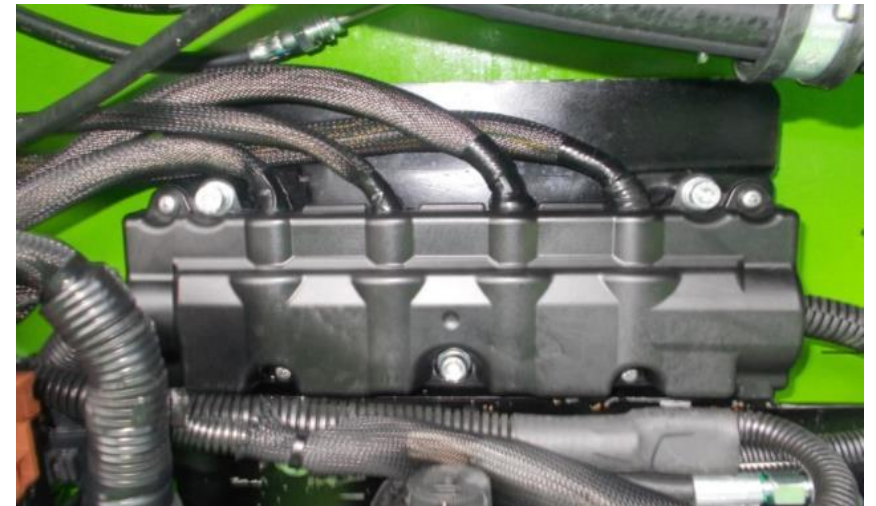
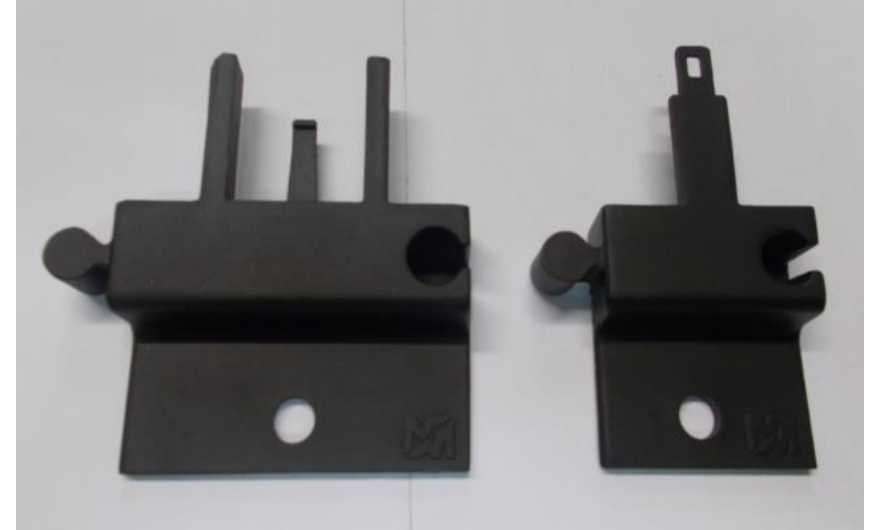

# Electrical system



Greater cleanliness and simplicity of the machine's electronic circuit.

The ROTO models are equipped as standard with AUTOMATIC and timed battery switches.



### ***Customer benefits:***

- ✓ Greater access for maintenance
- ✓ Easier to use, no need to think about the battery disconnecting switch

# Electrical system

Engine control unit and UCTI control unit positioned in the engine compartment.

Electrically/automatically operated battery disconnect switch mounted at the front or rear depending on the range. There is a safety fuse on the battery for complete disconnection of the electrical circuit.

## **Customer benefits:**

- ✓ Increased vehicle automation
- ✓ Longer life for batteries and electric circuits
- ✓ Safer





# Safety system



Active safety system, guarantees stability both operating on wheels and on stabilisers. Based on the stability index, it adjusts the maximum boom handling speed.

# Safety system - ASCS parameters

---



For the determination of the stability index, the load diagram of the machine is compared with the following measured parameters:

- Load position: boom angle and extension, turret rotation, carriage rotation.
- Position of stabilisers (ROTO S-Plus)
- Tool in use: automatic tool recognition.
- Handled load: weight of load lifted.

# Safety system



As additional safety, the load is constantly monitored at each support point of the machine on the ground (wheels or stabilisers).

This second system intervenes in extreme situations (stabilisation on slopes, loss of adherence) by inhibiting the aggravating movements when approaching the stability limit.



# EN15000

---

To ensure stability, all Merlo machines are equipped with two sensors in the rear axle to read the amount of load on each of the wheel hubs, hence preventing the machine from tipping over at the front.

In addition, all machines are equipped with a load limiter capable of communicating with the load sensor on the implements to preserve the structural integrity of the equipment.

## ***Customer benefits:***

- ✓ Excellent operator safety
- ✓ Easy to use and manage
- ✓ Optimal equipment management





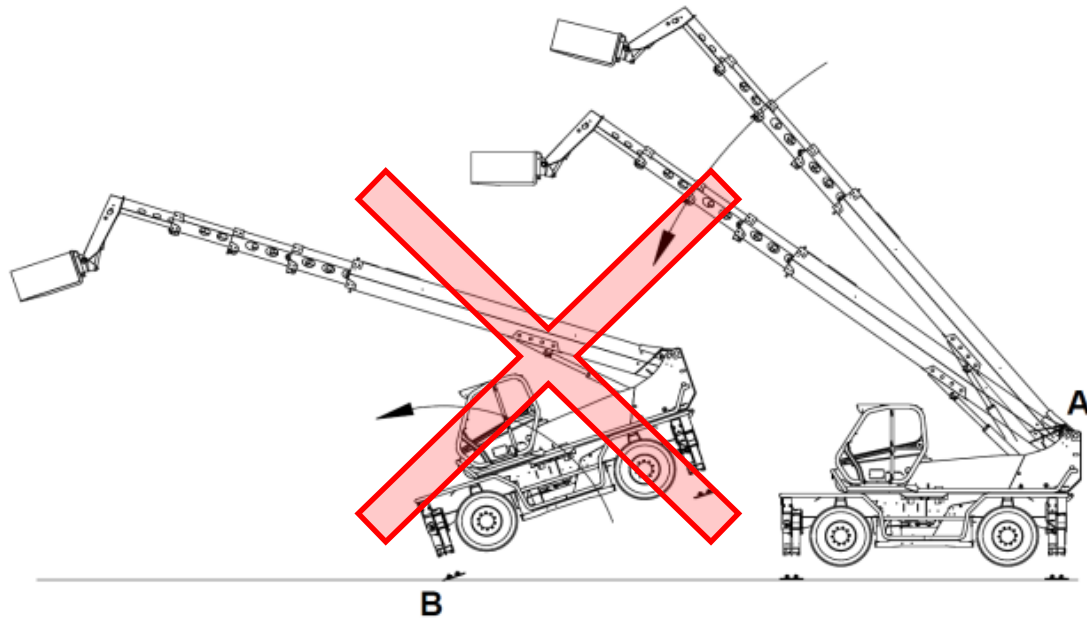

# EN15000

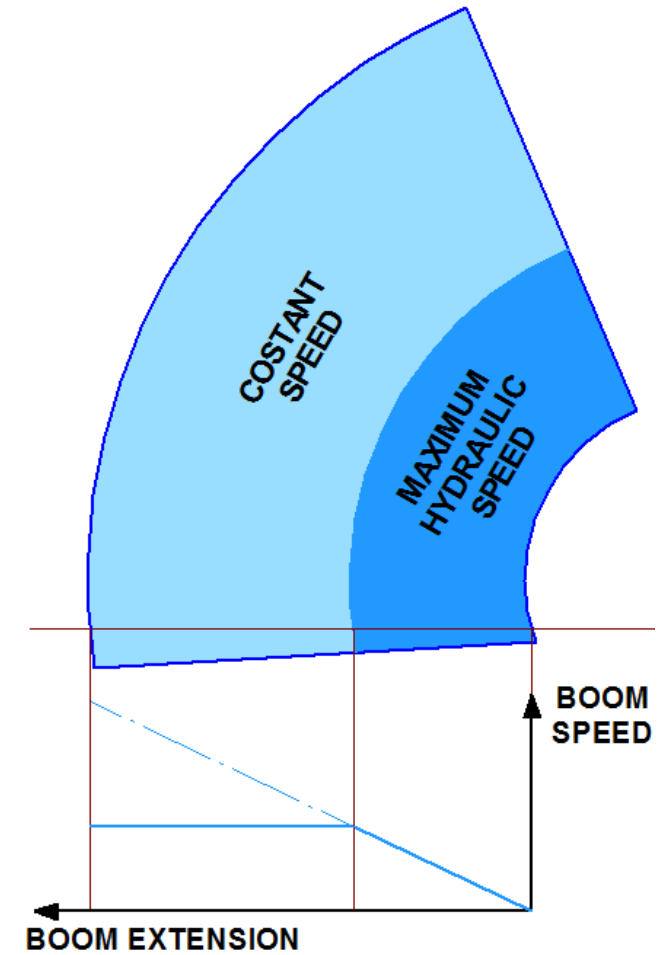

To comply with EN15000, a constant downstroke speed (m/s) is guaranteed to avoid overturning risks.



# Pick & Carry

-  80% of capacity
-  100% of capacity

**CROSS VIEW FRONTAL**

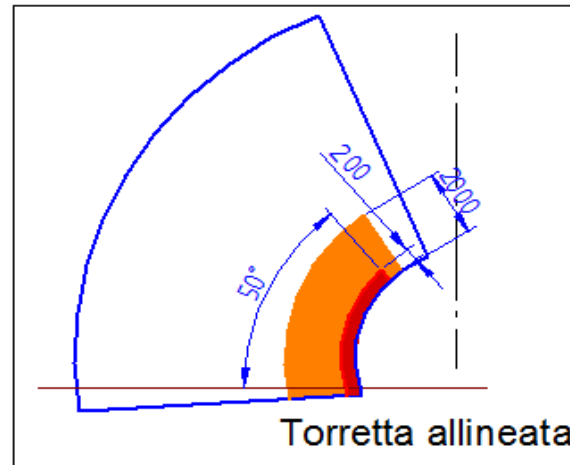

**CROSS VIEW LATERAL**

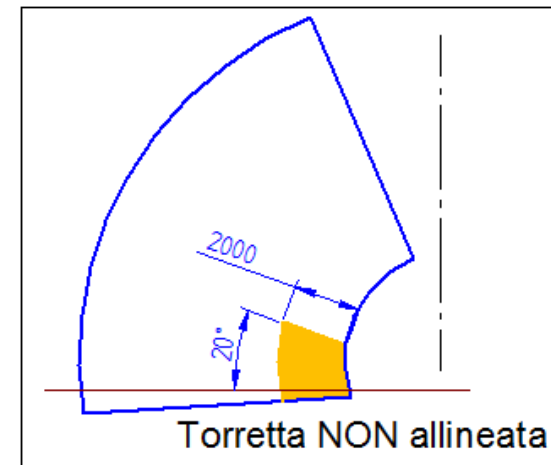

Possibility of stabilising and removing the stabilisers with both front and side turrets to simplify Pick & Carry operations.

**ATTENTION:** all the ROTO ranges include the possibility of driving the machine (maximum speed of 5km/h) even with extended stabilisers.

# ASCS: Adaptive Stability Control System

The system operating principle is based on three parameters:

- **Handled load** - kg of material lifted (read by a load cell)
- **Load position** – calculated by means of special sensors that read the extension, the boom lifting angle and the carriage rotation angle
- **Implement in use** - automatically recognised by the ASCS system.



# Implement recognition

---

## HOW RECOGNITION TAKES PLACE:

The attachments are recognised by means of a sensor located at the rear of the TreEmme attachments. Recognition takes place without a direct electrical connection between implement and machine. The receiver on the machine carriage recognises the type of attachment and sends this information to the ASCS system.





# Implement recognition

## WHAT THE MACHINE DOES:

The ASCS software processes the information arriving from the sensors as indicated above and internally creates a dynamic and virtual load diagram within which all the operating conditions of the machine combined with that specific attachment are managed.

When the operational stability limit (load diagram limit) is reached, the system first reduces the speed of the boom and then stops movement completely. In this phase, only those movements that do not compromise vehicle safety and stability are permitted and possibly displayed, thus simplifying the use of the machine even for less experienced users.



# ASCS - Premium

The **ASCS Premium**'s navigation system is operated via a knob located on the right-hand armrest near the joystick.

The colours identify the activation status of a control:

- black background: command not selected.
- white background: command selected but not yet active.
- light blue background: command active.

To scroll through the various panels shown, it is necessary to turn the knob and confirm the choice by pressing it.



**SELECTION  
KNOB**

# ASCS OPT: camera

The ASCS display is also used for the cameras.

By pressing the knob on the camera window, the display switches between standard and full-screen mode (and vice versa).

In the event of an error, the screen colours indicate:

- light blue, a fault in the selected camera
- red crossed-out camera, no camera is installed.



**REAR CAMERA (opt)**



**CAMERA 2 (front - opt)**





# Display

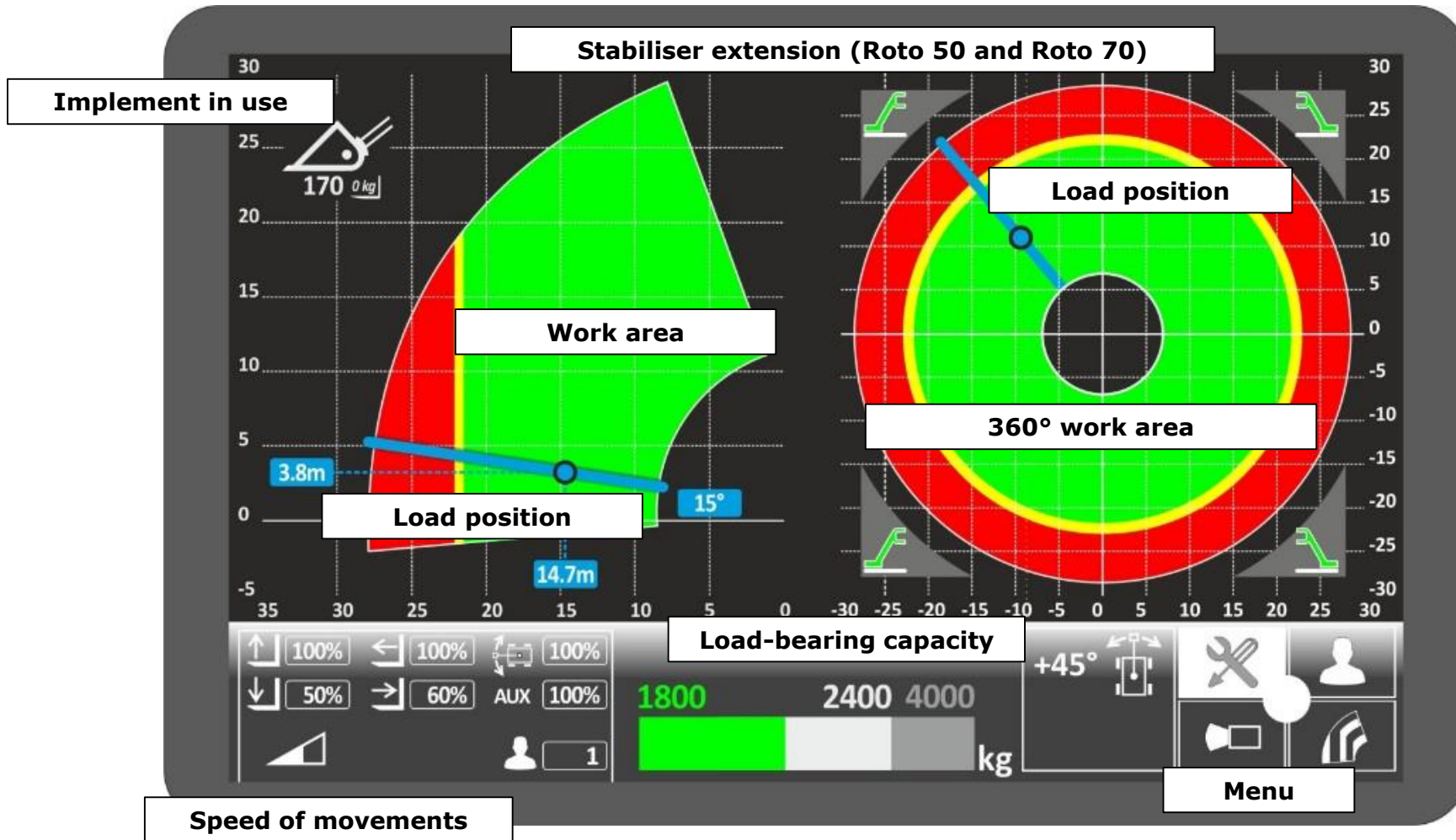

The ROTO view also provides a top view of the work area, so that the turret rotation is always under control and limits can be set all around the machine.



# Work area and load diagram

The system shows the load diagram for the active work configuration in real time. The attachment in use is graphically represented in the upper part of the screen.

With the load in the green zone of the diagram, all movements are possible and stability is maximum.

With the load in the yellow zone, stability is maximum but movements are automatically slowed down.

With the load in the red zone, the machine has reached the limit beyond which stability is no longer assured. At the same time, the automatic locking of movements that could worsen the situation, and the acoustic and visual safety alarms are triggered.

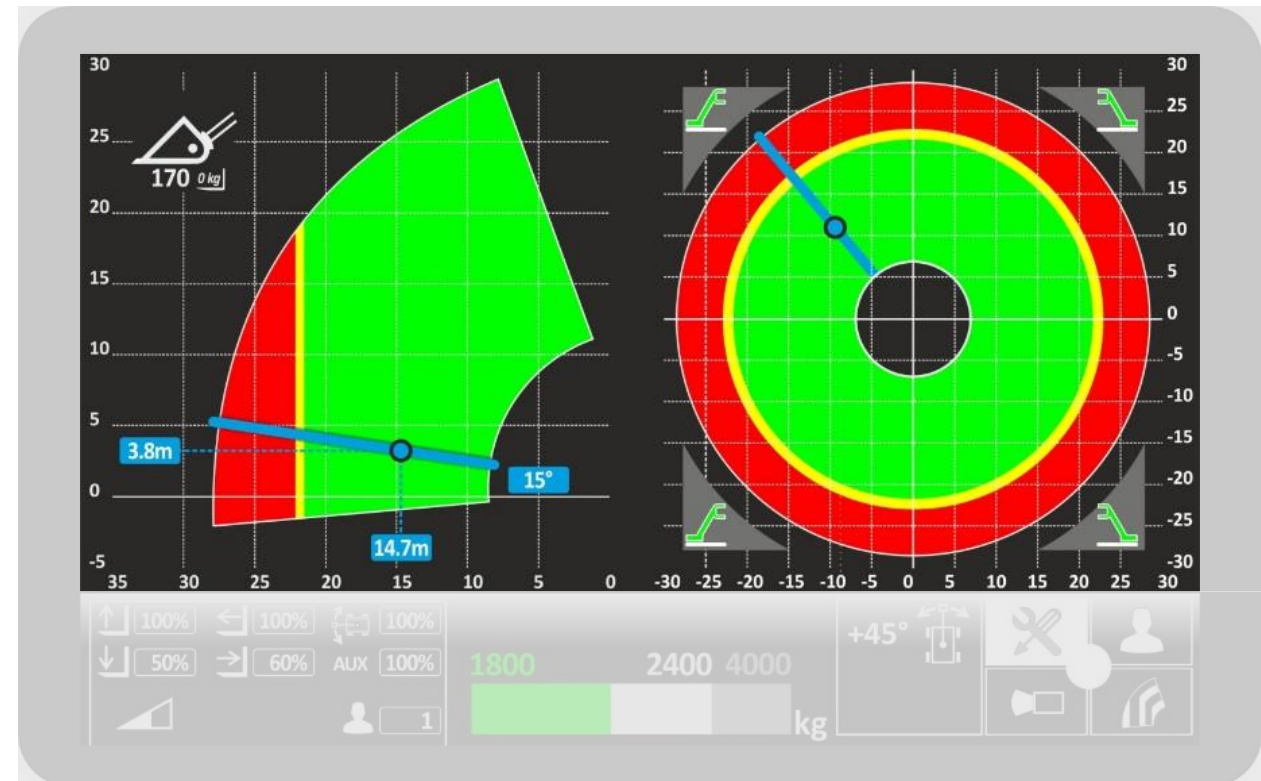

# Movement lock

In case of movement lock, a pop-up shows the customer the movements that can still be performed to simplify the management of the machine.

There are **27 possible combinations**, obtained by the different combinations of extension/retraction, up/down movements of the boom, carriage rotation and auxiliary up/down movements.

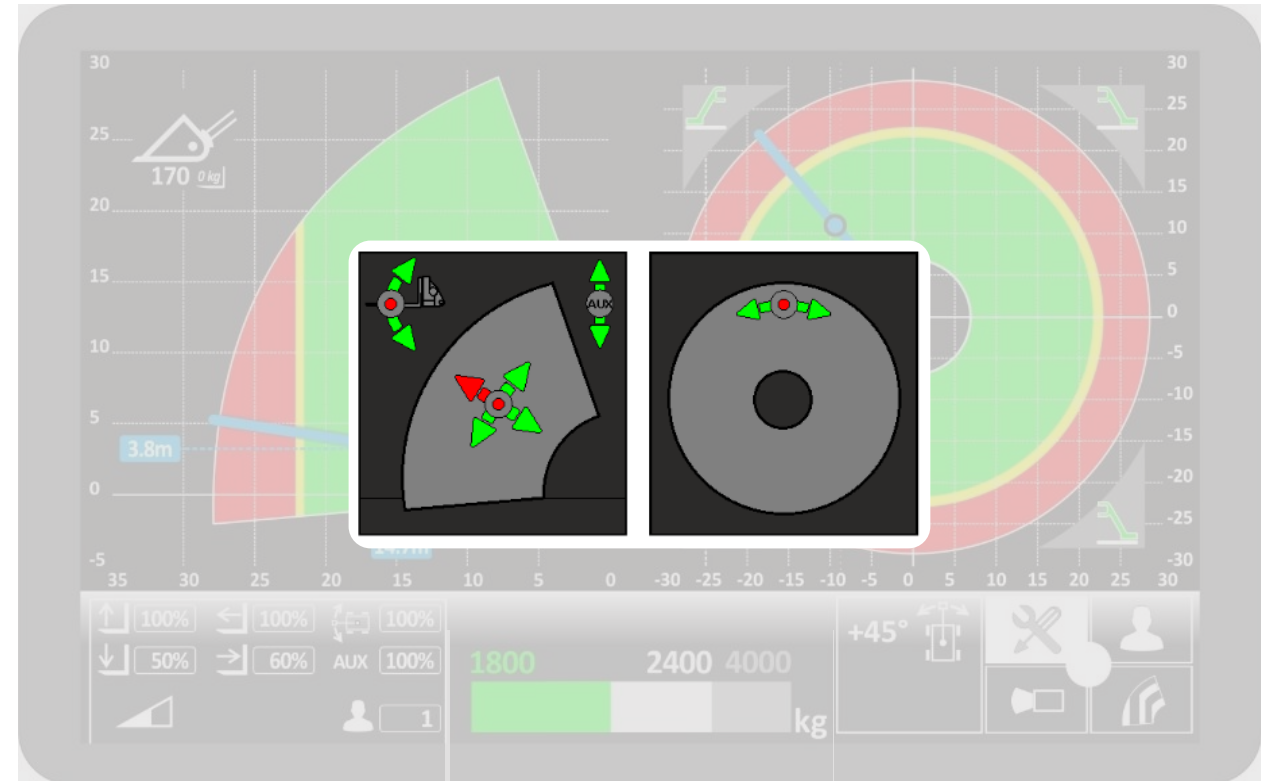

# Stabilisation indicator

In the corners of the work area box seen from above, icons show the stabilisation status of the machine.

The icons, which may represent a wheel or stabiliser, turn red in the event of instability.



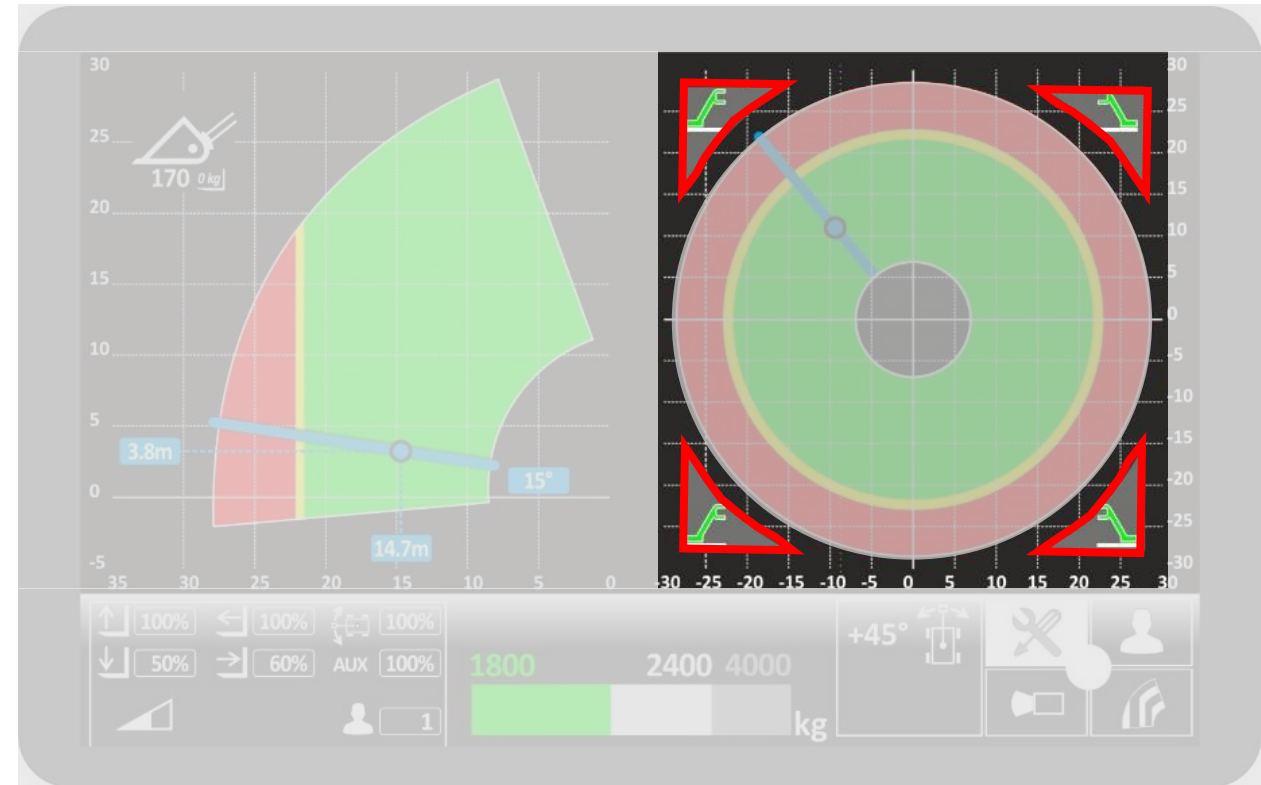

There is also an indication of the extension of the stabiliser and whether or not it is touching the ground.

If one of the stabilisers loses contact with the ground, the machine can only continue working in the unaffected part of the diagram. This allows work to be completed and system to return to a safe condition.



# Customising functions

The system allows the user to customise the speed of individual movements of the telescopic boom and the attachments according to the needs of individual operators (up to six settings).

-  BOOM UP/DOWN MOVEMENT
-  BOOM EXTENSION/RETRACTION
-  TRANSLATION and AUXILIARY MOVEMENT
-  OPERATOR ID

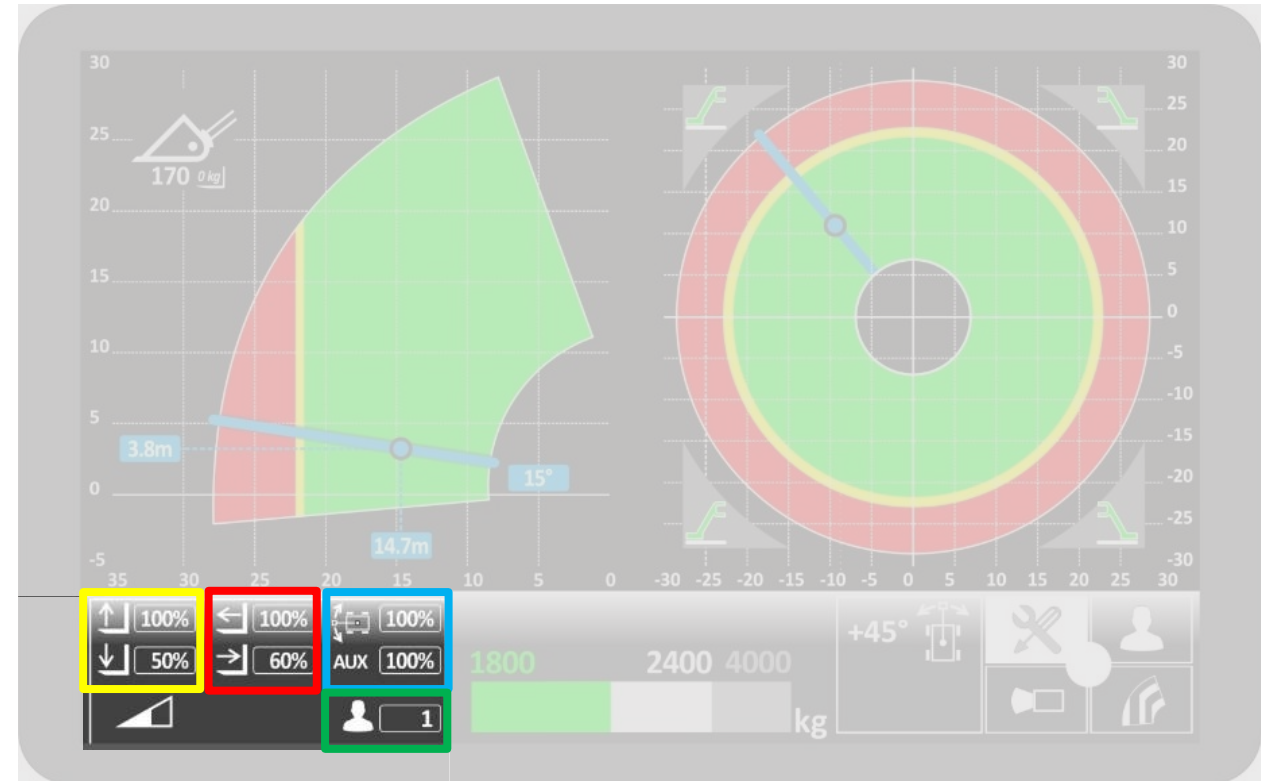



# Performance - Capacity

The operator can view the details about the machine load capacity.

- The mass of the load is shown on the left.
- The maximum capacity in the operating situation is shown in the middle, in white.
- On the right, in grey, is the maximum capacity with that particular implement.

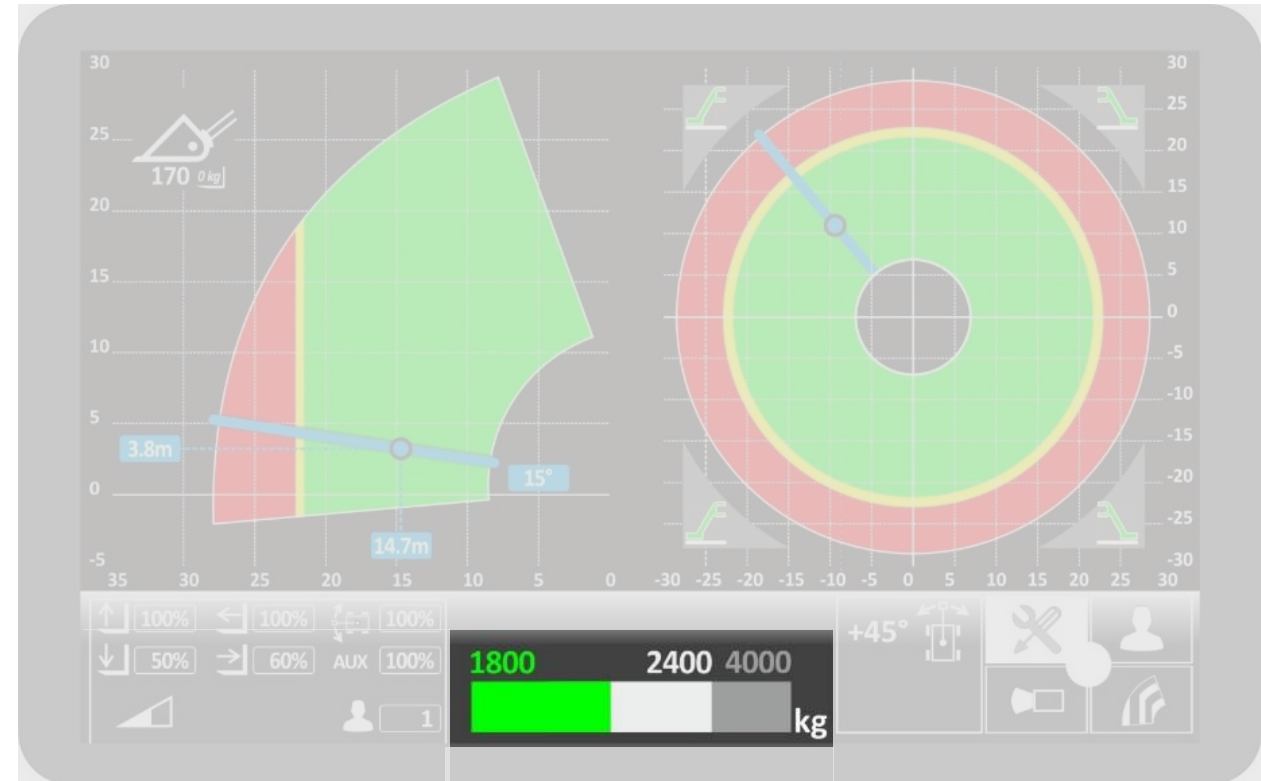

# Safety – Levelling

A (digital) spirit level provides real-time information on the current machine alignment, both lengthwise and crosswise.

The degrees of inclination of the frame are shown at the bottom.

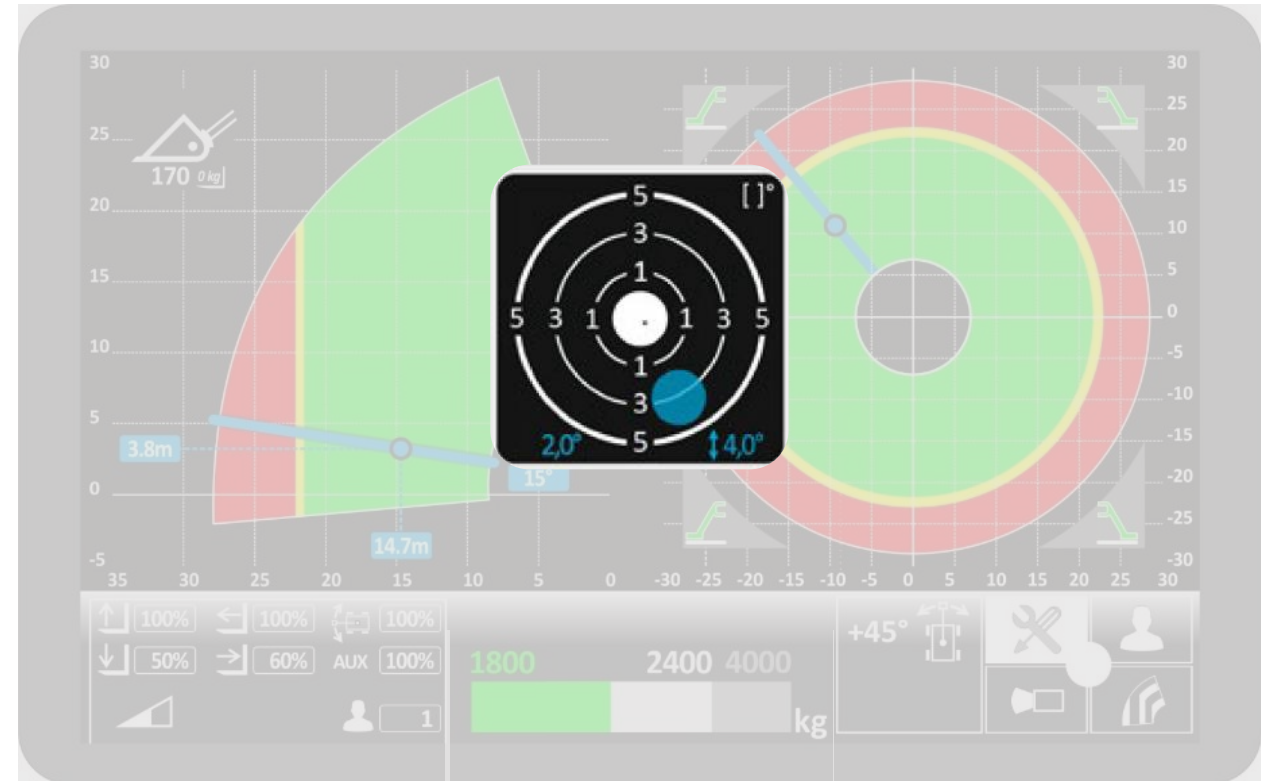

# Work area management

Like for frontal telehandlers, it is possible to set the work area, managing limits within which the boom can operate. Limits can be managed in either a Cartesian or a geometric way.

- Extension limit
- Lifting limit
- **Rotation limit**

**Pros:** Greater speed of use and machine management, increased operating comfort for repetitive work and increased work safety in hazardous environments.

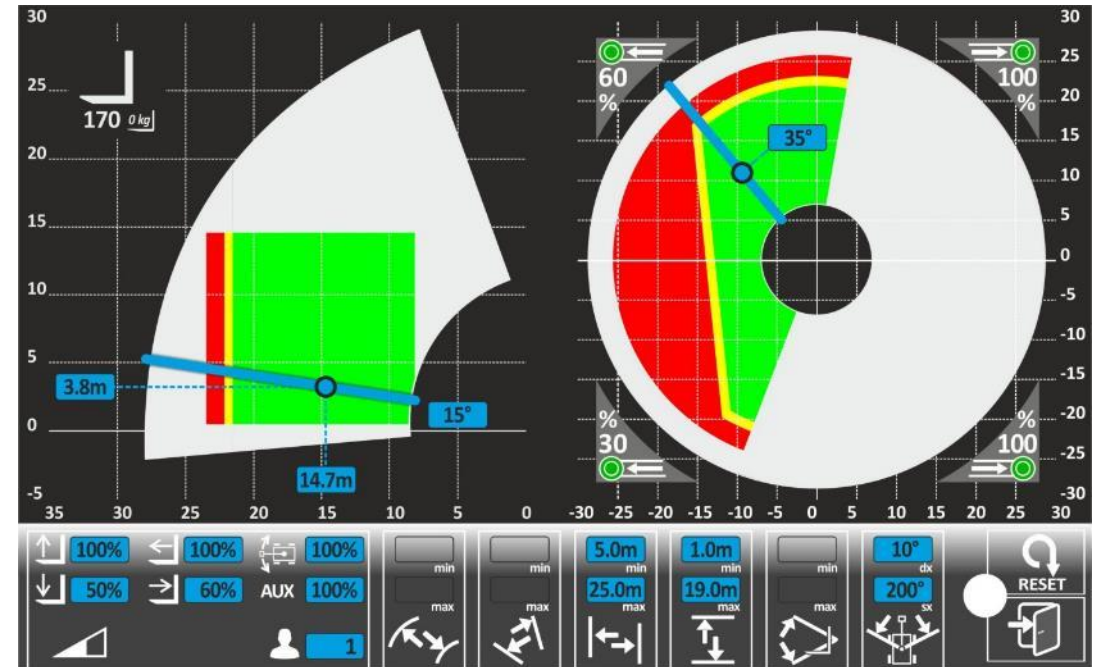

# ASCS Plus

The ASCS safety system sets the load diagram with two different solutions, a STANDARD one and a PLUS one.

## Standard

- ROTO 40.16 (all)
- ROTO 40.18 (all)
- ROTO 50.21
- ROTO 50.21 S
- ROTO 50.26
- ROTO 50.26 S

## Plus

- ROTO 50.21 S (Optional)
- ROTO 50.21 S Plus
- ROTO 50.26 S (Optional)
- ROTO 50.26 S Plus
- ROTO 50.30 S
- ROTO 50.30 S Plus
- ROTO 70.24 S
- ROTO 70.24 S Plus
- ROTO 50.35 S Plus
- ROTO 70.28 S Plus

The same scenario also applies to EE and EE4 versions



# Simplified safety system

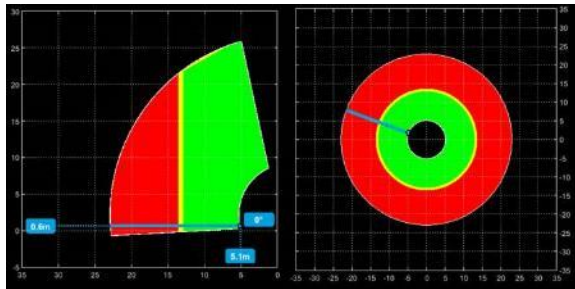

Stabiliser at 100%

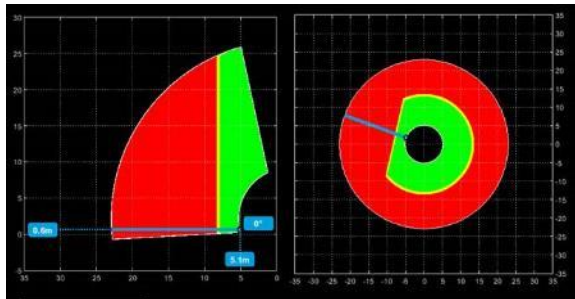

Stabiliser at 80%

Stabiliser at 50%

Stabiliser at 0%

For work with forks, hooks and shovels, the **simplified safety system** only recognises two stabiliser positions (regardless of the physical position actually set).

It sets the maximum working area in relation to the position of each stabiliser.

This solution is fitted to ROTO50.21S and ROTO50.26S models.

# PLUS safety system

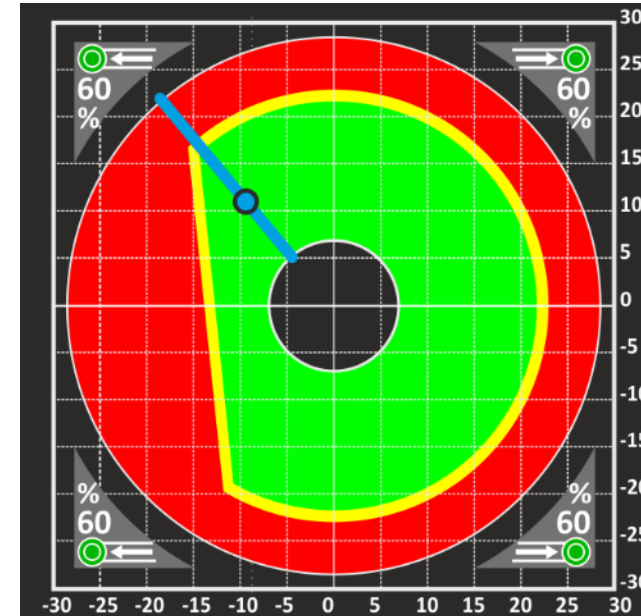
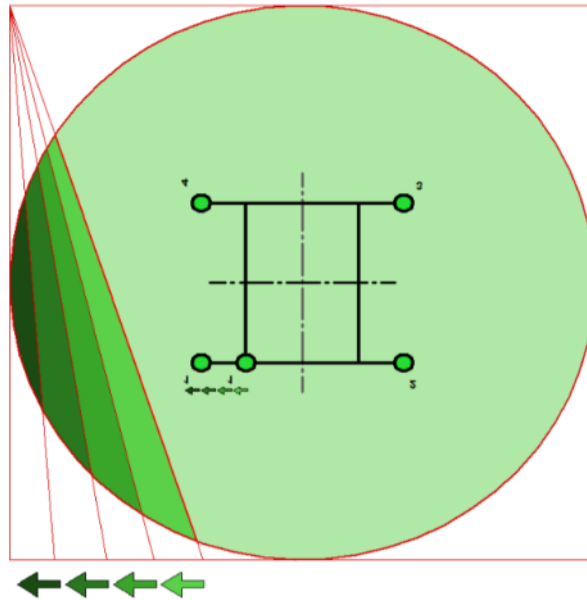

The **PLUS safety** system, thanks to a magnetostrictive sensor, allows the system to know precisely the position of each stabiliser, calculating the safety margins accordingly and thus allowing an adaptive load diagram to be obtained according to the geometric configuration of the stabilised footprint.

# Comparison

The PLUS system allows a better load diagram to be obtained when working with partially retracted stabilisers.

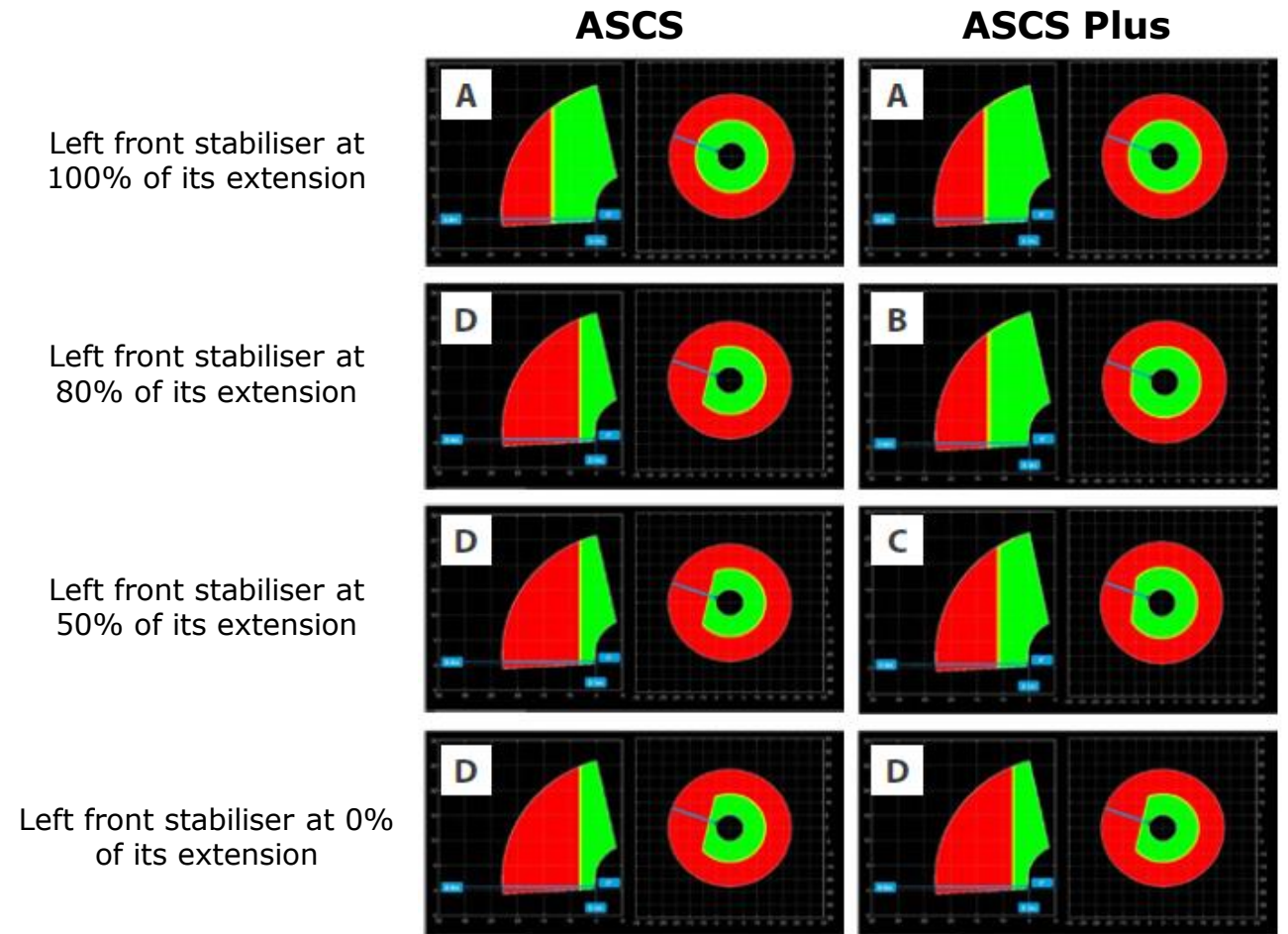

# Boom and hydraulic system



# Hydraulic pump

---

**Variable displacement hydraulic pump - Load Sensing with Flow Sharing control** (latest generation - with **Stepper Motor**), controlled by an electronic joystick control.

Maximum **pressure** of **250 bar**.

Maximum **flow rate** from 105 to 160l/min.



# Stepper motor

---

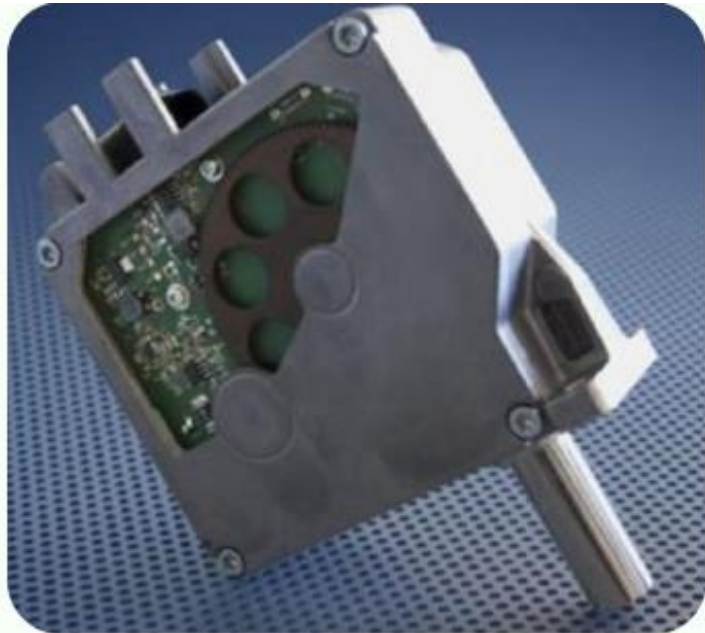

Solution with **Stepper Motor** that allows increasing hydraulic circuit reactivity and eliminating problems related to the temperatures and oil contamination. Valve opening is electrically controlled, unlike competitor solutions with hydraulic piloting.

### ***Customer benefits:***

- ✓ Multiple simultaneous movements, more precise movements
- ✓ Greater system efficiency for lower consumption
- ✓ Less degradation and overheating of components and oil

# Hydraulic



**Rear** mounted **Flow-sharing hydraulic distributor**, with stepper-motor solution, for boom movements and auxiliary movements, with priority valve for steering. This solution allows up to 3 movements to be carried out simultaneously without difficulty and reduces vibrations and noise in the cab.

Hydraulic distributor, hydraulic lines and connections are dimensioned to reduce the effects of wear and overheating of the hydraulic oil.

### ***Customer benefits:***

- ✓ Greater accessibility in case of maintenance
- ✓ Less vibrations and overheating within the cab
- ✓ Greater efficiency and better cleaning of the hydraulic circuit.



The SHPD sensors monitor the precise position of each valve of the distributor, allowing the management of the "safe spool block" in case of anti-tipping system. This allows movements to be locked electronically (rather than hydraulically as in the past), ensuring that movements not detrimental to the stability are always managed directly from the joystick control (without using the red by-pass key).

***Customer benefits:***

- ✓ Simplified hydraulic system
- ✓ Greater control and safety



# Hydraulic tank

Hydraulic and hydrostatic fluid circuits are completely independent. There are **two dedicated tanks**, one for hydraulic fluid and one for hydrostatic fluid.

In this way it is possible to improve fluid cleaning and cooling and reduce the total amount of fluid required.

As standard, oil with a viscosity of 46 mm<sup>2</sup>/s is used. Synthetic biodegradable oil available as OPT.

## ***Customer benefits:***

- ✓ Less maintenance costs
- ✓ Lower risk of oil pollution and overheating
- ✓ Increased component service life

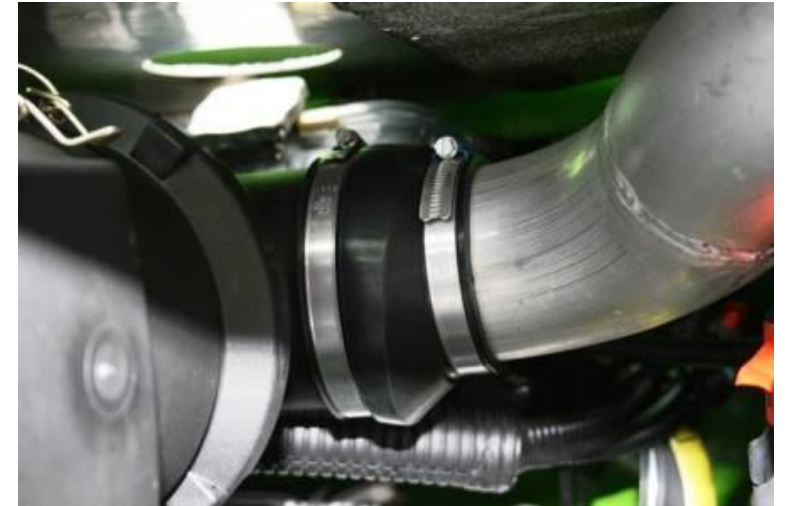



The layout is completed with a precise positioning of the pipelines in order to maximise service life and reduce wear and tear.

Finally, the machines are equipped with **PATENTED** Merlo **hydraulic couplings** to speed up the assembly and disassembly time, thus facilitating maintenance.

***Customer benefits:***

- ✓ Streamlined hydraulic circuit layout
- ✓ Quick disassembly and assembly
- ✓ Precision in connections

# Boom



Boom position designed to improve visibility in all conditions.  
Carriage designed to improve digging force and visibility on forks and tools.

### ***Customer benefits:***

- ✓ Better side, rear and front visibility on tools
- ✓ High digging force and rotation angle of the carriage
- ✓ Strong and lightweight boom structure.

# Boom



Two «C-shaped» elements welded along the neutral inclination axis. Welding is carried out in the area with the least stress.

The section is resistant and sturdy, allowing to reduce the size of the boom and allowing the creation of lateral holes to lighten the structure and improve the maintenance inspection.

## ***Customer benefits:***

- ✓ Greater structural rigidity
- ✓ Greater work area thanks to the lighter boom
- ✓ High precision in movements and extensions thanks to the absence of inclination



# Boom

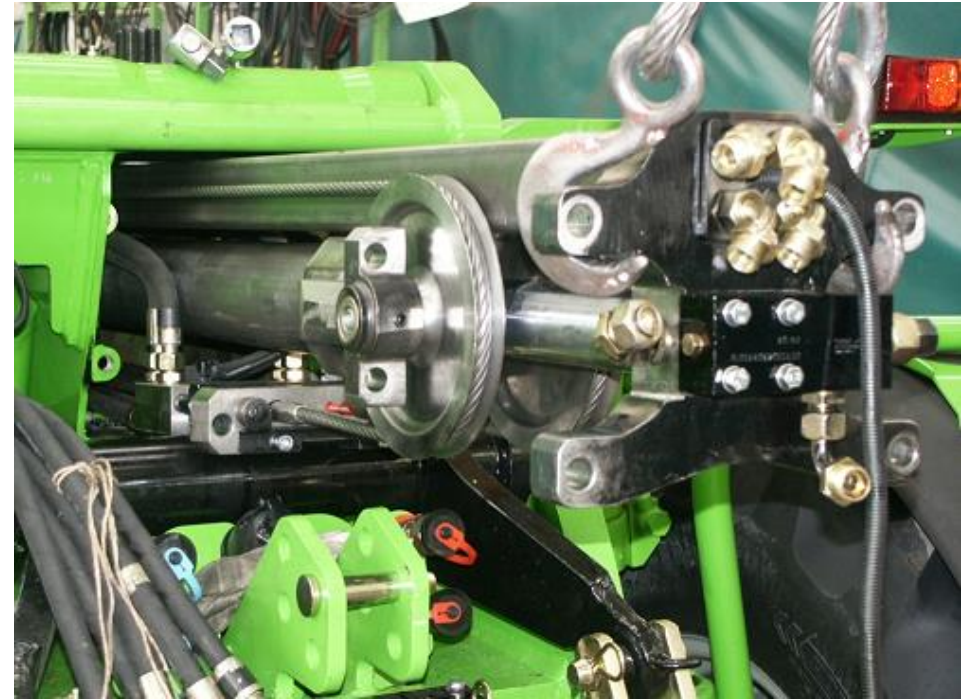

Rigid boom, no downward inclination.

All the components are inside the boom , in a position protected from bumps and damage, assembled in a «cartridge» system to simplify maintenance. It improves visibility from the cab.

# Boom extension

---



Boom extension with chain and rope mechanism. It allows a simultaneous, fast and precise extraction of the different boom sections. It is possible to fully extend the boom even when working on wheels. Chain size has been adjusted to increase machine's load-bearing capacity, and the design safety coefficient has also been increased.

# Sliding pads



## «L-shaped» sliding pads.

They improve contact on the boom, keeping it in position and simplifying the adjustment in case of wear.

### ***Customer benefits:***

- ✓ Greater simplicity of adjustment
- ✓ Less need for lubrication
- ✓ Better boom-sliding pad contact

# Lifting

---



Lifting cylinders designed to work with higher pressures. Significantly increased component life and drastically reduced risk of hydraulic leaks.

***Customer benefits:***

- ✓ More performance
- ✓ Increased component service life
- ✓ More product quality



# Carriage



The rotation mechanism of the carriage (ZM2) has been designed to ensure a high rotation torque.

Pins and bushings, with increased diameter, to increase the service life of the wear components.



***140-degree rotation of the carriage.***

# Tac-lock

The Tac-lock system is the solution for locking the implements, **hydraulically** controlled from the cab.

It allows you to change implements without leaving the cab, safely and quickly, and is available as **standard** on all models by Merlo. To operate the tac-lock you need to control the movement with the joystick and, at the same time, push the red button on the dashboard to enable it.

## **Customer benefits:**

- ✓ Easier to use
- ✓ Safer
- ✓ Less idle time upon implement change-over

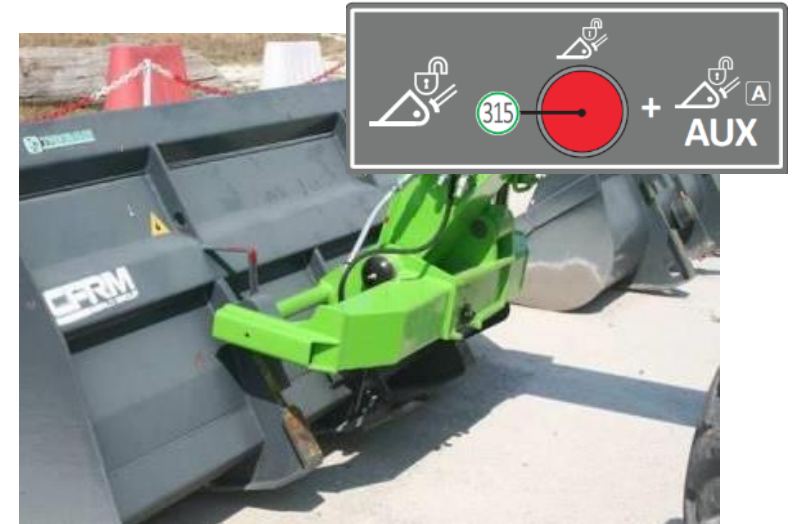

# Implement interface

---



Electrical connection on top of the standard boom on all ROTO machines.

It also allows the exchange of information between the machine and the tool to:

- Implement more hydraulic movements
- Limit the lifting load



# Aerial work platform lock

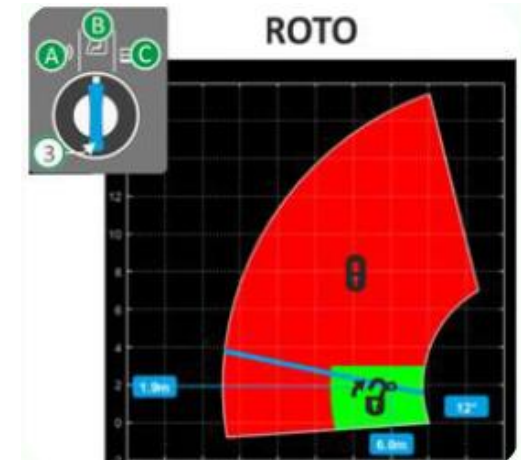

## **STANDARD pre-arrangement for aerial work platform** on all machines.

If the aerial work platform is used, the use of a mechanical locking pin equipped with a sensor is required. With a recognised platform, if there are no loads on the platform, you can move the boom in any position whilst operating from the cab. If a load is present, a safety limitation is inserted at a height of three metres.



# Main equipment

# Self-stabilisation and self-levelling

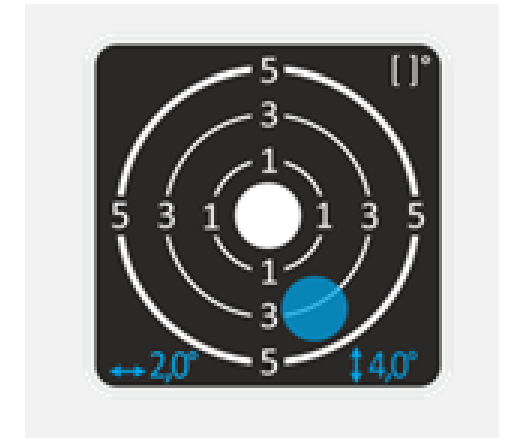

ROTO machines are equipped as standard with **SELF-STABILISATION** and **SELF-LEVELLING**.

## *Customer benefits:*

- ✓ Greater ease of use of the machine
- ✓ Less wasted time for the stabilisation phases
- ✓ Possibility of correcting transversal and longitudinal slopes

# Radio Control

---

Radio control (code A1793) for the use of aerial work platforms and for the remote implementation of hydraulic movements. Housing in the cab for the radio control with battery charging mechanism.

The radio control allows you to:

- **Remotely control hydraulic movements** for jobs with lifting equipment;
- **Perform hydraulic movements from control panel** for jobs with aerial work platforms for carrying persons.



# Plates for stabilisers



The ROTO machines with «multi-position» stabilisers are equipped as standard with plates to increase the support surface, reducing ground pressure.

Ideal for work on softer grounds.



# Machine warranty

---



The Merlo ROTO machines are distributed with an extended manufacturer warranty of 2 years or 2.400 h.

# MerloMobility

**La solution**  
**MERLO MOBILITY**

**MERLO**  
ADVANCED TECHNOLOGIES  
www.merlo.com

**Gain de temps et de carburant**  
Permet de savoir où est votre machine  
Permet la planification, le contrôle et la programmation des activités  
Optimisation de la machine lors des déplacements

**Gain en coûts d'entretien et diagnostic**  
Permet un contrôle préventif  
(Niveau d'usures, T° moteur, Pression d'huile, Données d'entretien, Données de charge...)  
Signaler les anomalies de la machine  
Diagnostic des éventuelles pannes à distance  
Stockage de toutes les informations importantes concernant le matériel

**Solution anti-vol**  
Définition des niveaux horaires de fonctionnement  
Alarme mouvement machine  
Notification d'effraction  
Alarme en cas de remorquage  
Alarme par E-mail en cas de manœuvre inappropriée ou sortie de la zone définie

MERLO France - 7 Rue des Saules - 91161 Lagny-sur-Marne  
Tel : 01 33 44 41 00 - info@merlo.com.fr

www.merlo.com

ROTO machines can be equipped with the **MerloMobility** system. Telematic system that allows:

- geolocalising the machine
- setting up a work area
- remotely monitoring the behaviour of the machine
- performing a machine system diagnosis.

Standard on all ROTO S-Plus models.

# Main OPT

# Work lights

---

The machine can be set up with four **work lights** (halogen or LED) mounted on the front and rear of the cab roof. The headlights are controlled by a special switch on the dashboard in the cab. They allow the work area to be illuminated following the movement of the machine's telescopic boom.

**Boom-mounted work lights** are also available, which allow the working area to be illuminated following the movement of the telescopic boom.





# Front glass protection

---

The front glass protection is provided by a **metal grille**, which prevents the windscreen from being smashed in the event of a collision or falling objects. The grille is easily removable from the top.

When driving on the road with a type-approved vehicle, this grille must be removed.



# Generator

---

**Generator** for the supply of electric current for aerial work platforms. For current transfer there is a cable winder on the side of the telescopic boom. The generation heat engine is 4kVA and 220V, and it is powered by a tank inside the application. It is possible to start the heat engine with remote control (radio control).



# Transfers

---



**Merlo:** during transfers, it is possible to house the fly jibs and winches on the frame. In this way, both when travelling by road and when transporting by truck, the implements move together with the machine.

# Roto Plug-In



# Electric power for the Roto

---

All Roto models can be equipped with an electric power system that allows them to operate under completely safe conditions, without using their combustion engines. This provides for significant benefits in terms of noise and pollutant emissions, as well as decreased fuel consumption.



# Structure: Electric power supply

The **system** consists of 4 elements:

- A control unit ([A])
- An electric motor ([B])
- A hydraulic pump ([C])
- A cable for connecting to the mains electrical system ([D])

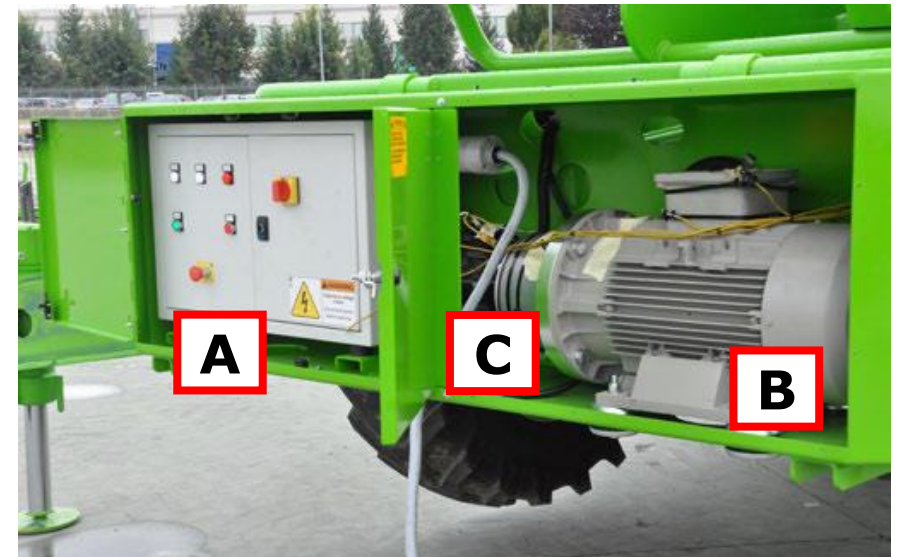
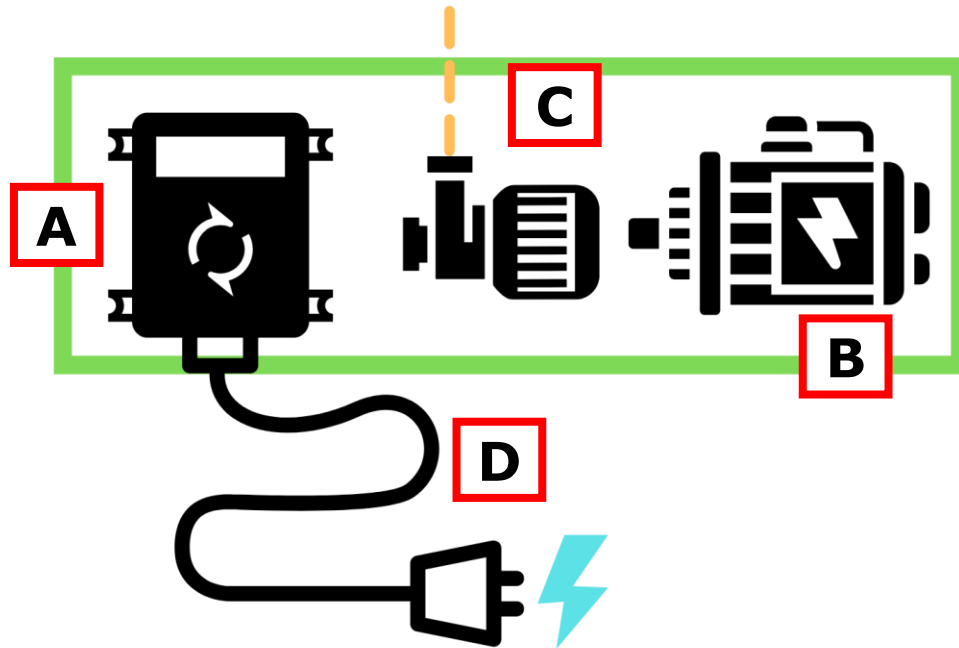

# Electro-hydraulic control unit

The **control unit** is located at the front of the machine's frame. To access it, the protective doors must be opened using the key supplied.

The control unit contains the electrical system's indicator lights, the start and stop buttons (even for emergency purposes), and the power supply type selector (diesel engine/electric motor).

**[A]** Main switch

**[B]** Power supply type selector (diesel engine / electric motor)

**[C]** Emergency stop button

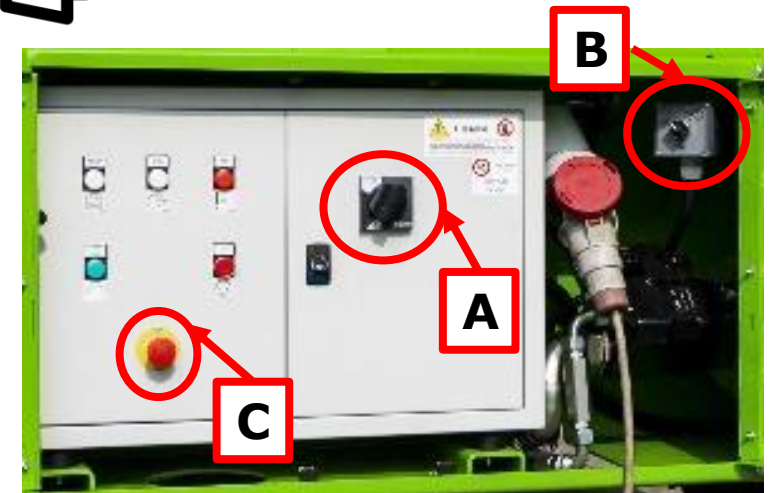
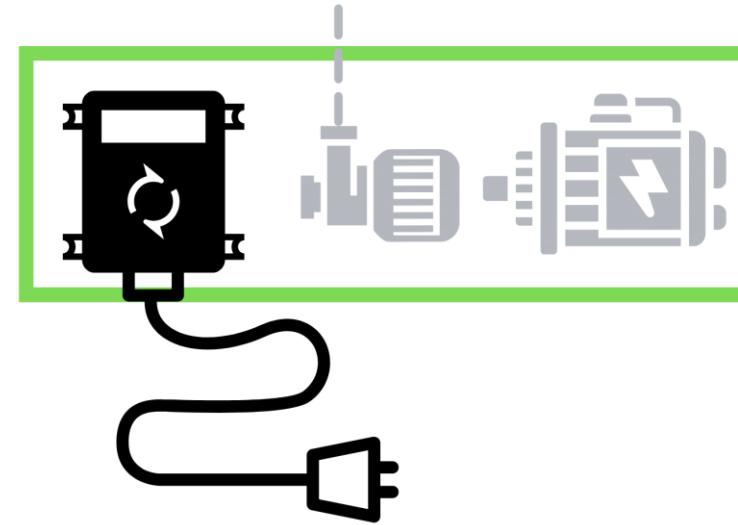

# Electric motor

The characteristics of the **three-phase asynchronous electric motor** are as follows:

**Power:** 22kW

**Speed:** 1.460 RPM

**Amps:** 38.8A 400V

**Torque:** 144Nm

**Power supply:** 32/64A

Motor used to power the hydraulic pump that will perform all the machine's hydraulic movements. Both solutions (32A/64A) come with a 50m cable.

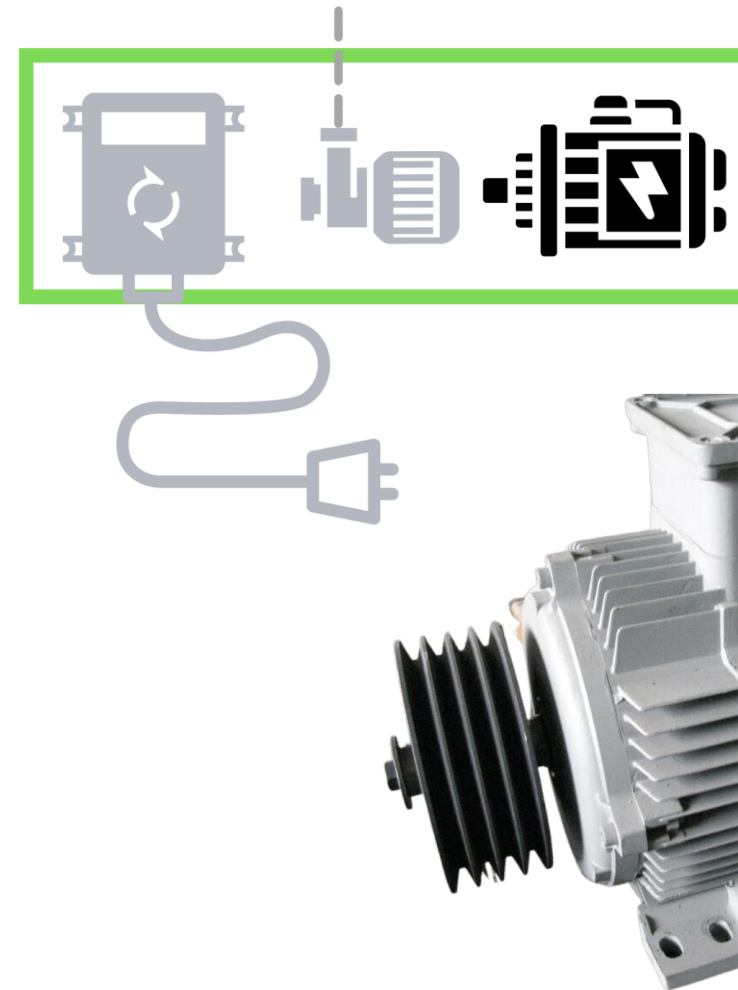



# Pump

The electric motor is connected to a **variable displacement hydraulic pump** capable of delivering a **flow rate of 70 L/min**.

The hydraulic pump connected to the machine circuit allows the following movements to be performed:

- Boom extension/retraction and ascent/descent
- Carriage rotation and engagement of auxiliary hydraulic movements
- Turret rotation
- Stabiliser positioning

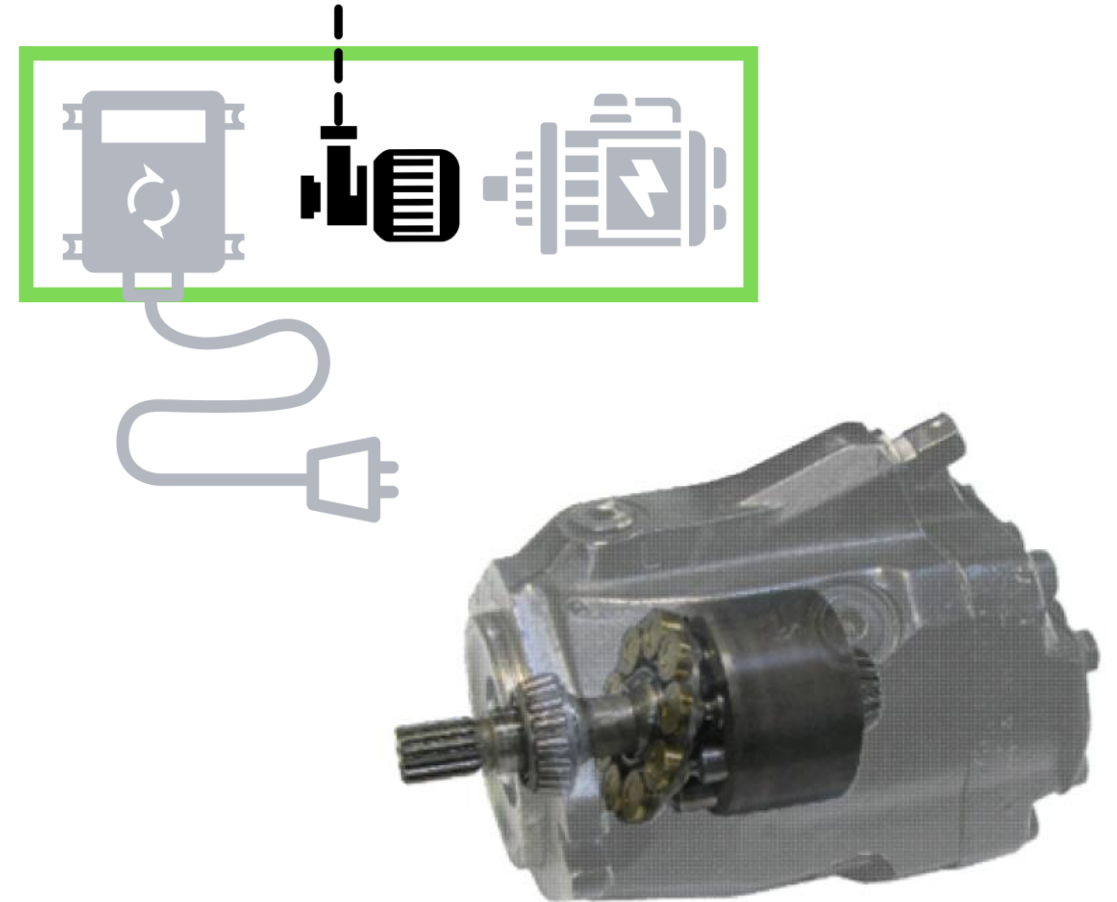

# Available movements

---

Using the electric motor, **all of the machine's standard functions are available**, with the exception of forward and reverse.

The machine can be controlled from the cab, from the aerial work platform, or by radio control.

When powered by the electric motor, the machine's functionality in aerial work platform or radio control mode is the same as when it is powered by the diesel engine in terms of performance.





**Thank you**